

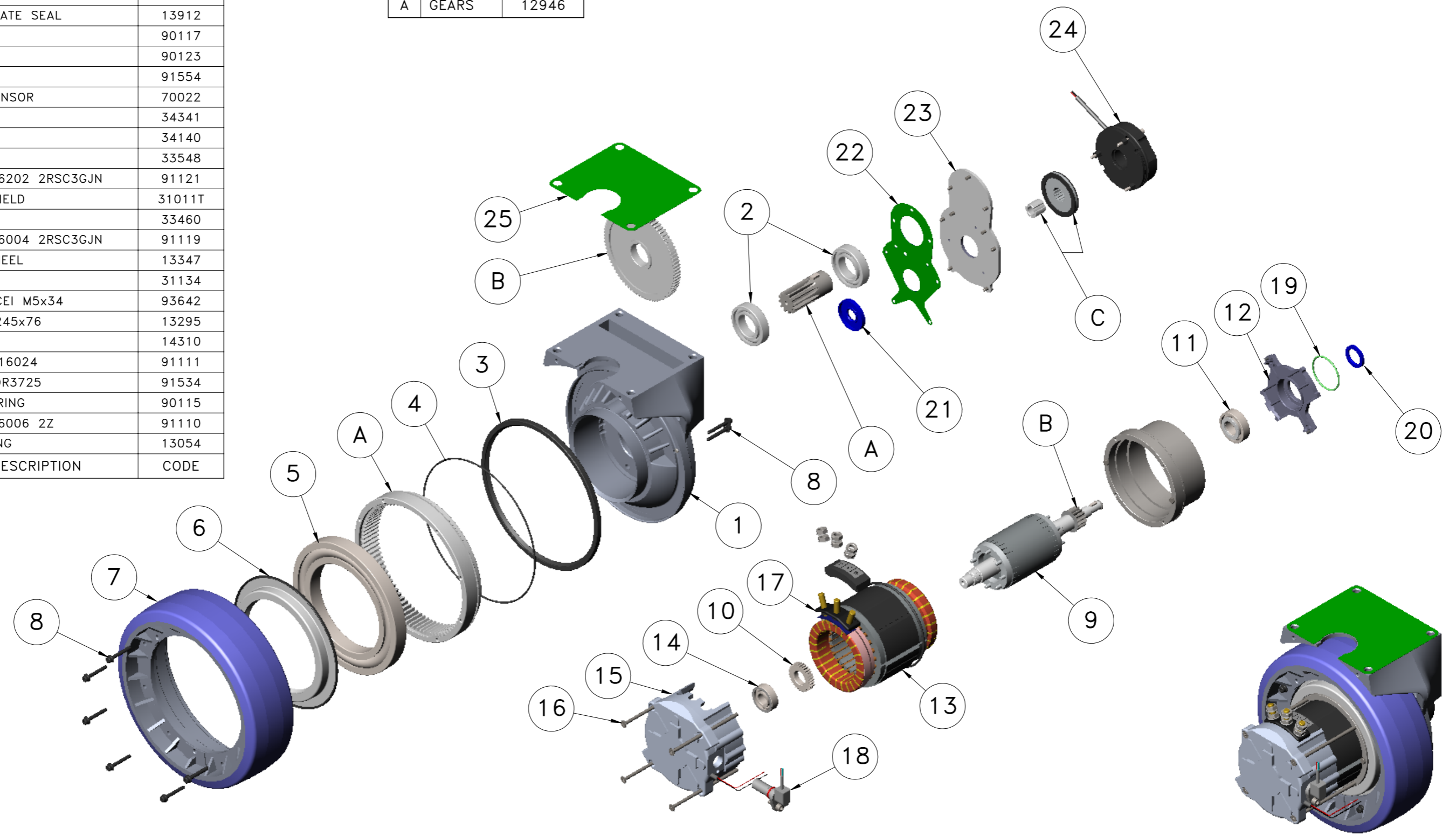

POS.	Q.TY	DESCRIPTION	CODE
25	1	GASKET	13902
24	1	BRAKE ø84CR	11114
23	1	BRAKE PLATE	13716
22	1	BRAKE PLATE SEAL	13912
21	1	SEALING	90117
20	1	SEALING	90123
19	1	OR 3168	91554
18	1	SPEED SENSOR	70022
17	1	BASE	34341
16	4	TIE ROD	34140
15	1	FLANGE	33548
14	1	BEARING 6202 2RSC3GJN	91121
13	1	STATOR FIELD	31011T
12	1	FLANGE	33460
11	1	BEARING 6004 2RSC3GJN	91119
10	1	FONIC WHEEL	13347
9	1	ROTOR	31134
8	12	SCREW TCEI M5x34	93642
7	1	WHEEL ø245x76	13295
6	1	SEALING	14310
5	1	BEARING 16024	91111
4	1	O-RING OR3725	91534
3	1	SEALING RING	90115
2	2	BEARING 6006 2Z	91110
1	1	AL CASTING	13054

C	FERODO	12914
B	GEARS	12903
A	GEARS	12946



DIS. <b>10172NT-E</b>	REV <b>00</b>	DISEGNATO AN Studio	VISTO	APPROVAZIONE U.T.E.	Rev	Visto	 Via Danimarca, 14/14 20093 Cologno Monzese - Milano - ITALY
		DATA 03/10/2012	SCALA 1:5	AGGIORNAMENTO STRUTTURA			
MODIFICHE							<b>SPAREPARTS A1C AC</b> <b>MOTOR CODE 30399NT</b>  24 Vcc / 1200 W WHEEL ø245x76 POLYURETHANE
0	EMISSIONE	05.10.12		AN			
						Project Nr.	-

CODICE 10172NT-E