

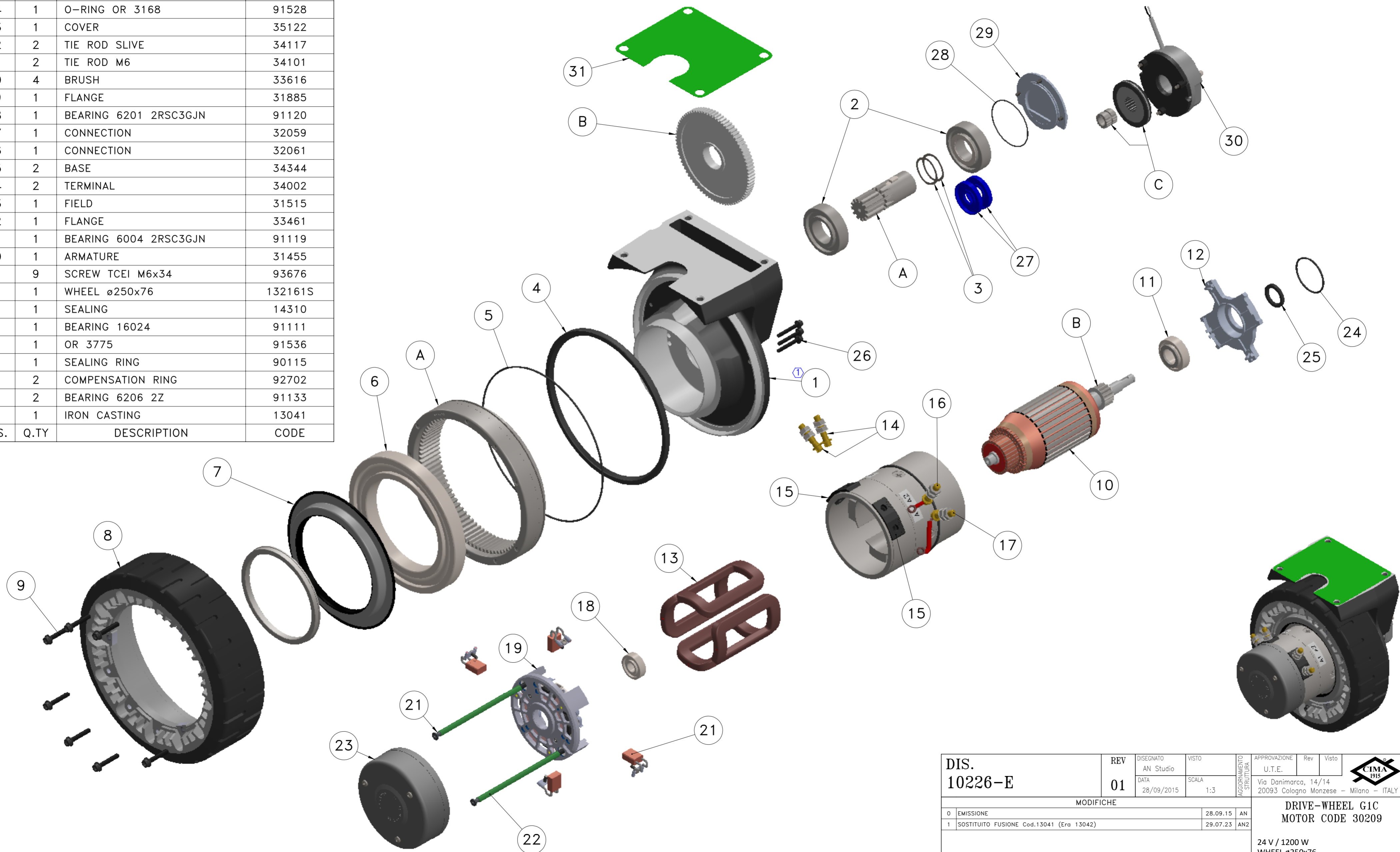

| POS. | Q.TY | DESCRIPTION | CODE |
|------|------|----------------------------|---------|
| 31 | 1 | GASKET | 13902 |
| 30 | 1 | BRAKE \varnothing 84SR | 11104 |
| 29 | 1 | COVER | 14104 |
| 28 | 1 | OR 2225 | 91556 |
| 27 | 2 | SEALING | 90117 |
| 26 | 6 | SCREW TCEI M5x34 | 93642 |
| 25 | 1 | SEALING | 90118 |
| 24 | 1 | O-RING OR 3168 | 91528 |
| 23 | 1 | COVER | 35122 |
| 22 | 2 | TIE ROD SLIVE | 34117 |
| 21 | 2 | TIE ROD M6 | 34101 |
| 20 | 4 | BRUSH | 33616 |
| 19 | 1 | FLANGE | 31885 |
| 18 | 1 | BEARING 6201 2RSC3GJN | 91120 |
| 17 | 1 | CONNECTION | 32059 |
| 16 | 1 | CONNECTION | 32061 |
| 15 | 2 | BASE | 34344 |
| 14 | 2 | TERMINAL | 34002 |
| 13 | 1 | FIELD | 31515 |
| 12 | 1 | FLANGE | 33461 |
| 11 | 1 | BEARING 6004 2RSC3GJN | 91119 |
| 10 | 1 | ARMATURE | 31455 |
| 9 | 9 | SCREW TCEI M6x34 | 93676 |
| 8 | 1 | WHEEL \varnothing 250x76 | 132161S |
| 7 | 1 | SEALING | 14310 |
| 6 | 1 | BEARING 16024 | 91111 |
| 5 | 1 | OR 3775 | 91536 |
| 4 | 1 | SEALING RING | 90115 |
| 3 | 2 | COMPENSATION RING | 92702 |
| 2 | 2 | BEARING 6206 2Z | 91133 |
| 1 | 1 | IRON CASTING | 13041 |

| | | |
|---|--------|-------|
| C | FERODO | 12914 |
| B | GEARS | 12903 |
| A | GEARS | 12944 |



| | | | | | | |
|--|-----------|------------------------|-----------------------|----------------------------|--------------|---|
| DIS. 10226-E | REV 01 | DISegnATO AN Studio | VISTO SCALA 1:3 | APPROVAZIONE U.T.E. | Rev Visto |  Via Danimarca, 14/14 20093 Cologno Monzese - Milano - ITALY |
| | MODIFICHE | | | AGGIORNAMENTO STRUTTURA | | |
| 0 EMISSIONE | | | | 28.09.15 | AN | DRIVE-WHEEL G1C MOTOR CODE 30209 24 V / 1200 W WHEEL \varnothing 250x76 RUBBER TRACED 70+72Sh |
| 1 SOSTITUITO FUSIONE Cod.13041 (Era 13042) | | | | 29.07.23 | AN2 | |
| Project Nr. - | | | | | | CODICE 10226-E |