

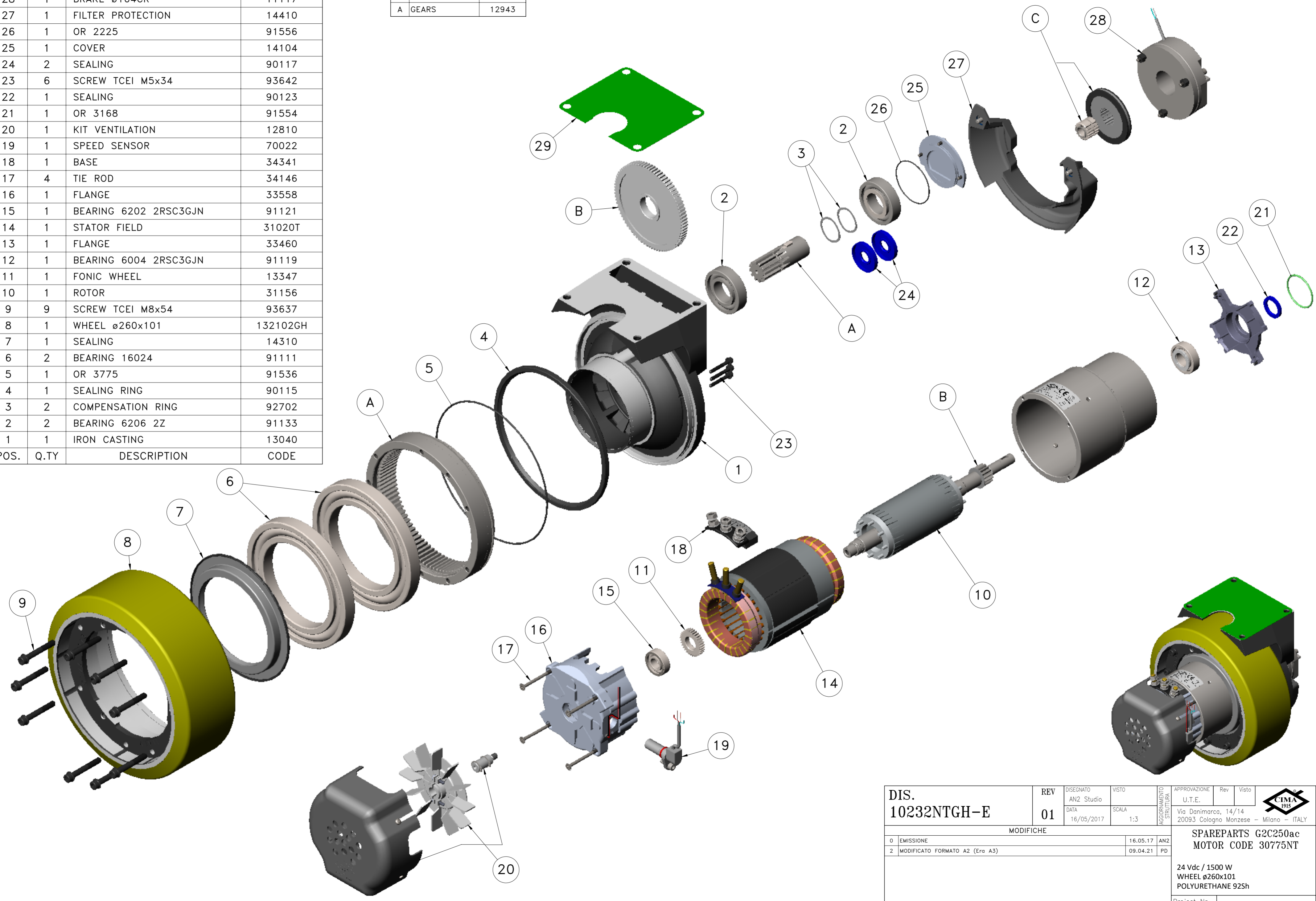

POS.	Q.TY	DESCRIPTION	CODE
29	1	GASKET	13902
28	1	BRAKE ϕ 104CR	11117
27	1	FILTER PROTECTION	14410
26	1	OR 2225	91556
25	1	COVER	14104
24	2	SEALING	90117
23	6	SCREW TCEI M5x34	93642
22	1	SEALING	90123
21	1	OR 3168	91554
20	1	KIT VENTILATION	12810
19	1	SPEED SENSOR	70022
18	1	BASE	34341
17	4	TIE ROD	34146
16	1	FLANGE	33558
15	1	BEARING 6202 2RSC3GJN	91121
14	1	STATOR FIELD	31020T
13	1	FLANGE	33460
12	1	BEARING 6004 2RSC3GJN	91119
11	1	FONIC WHEEL	13347
10	1	ROTOR	31156
9	9	SCREW TCEI M8x54	93637
8	1	WHEEL ϕ 260x101	132102GH
7	1	SEALING	14310
6	2	BEARING 16024	91111
5	1	OR 3775	91536
4	1	SEALING RING	90115
3	2	COMPENSATION RING	92702
2	2	BEARING 6206 2Z	91133
1	1	IRON CASTING	13040

C	FERODO	12913
B	GEARS	12903
A	GEARS	12943



DIS. 10232NTGH-E	REV	01	DISEGNATO	AN2 Studio	VISTO		APPROVAZIONE	U.T.E.	 Via Danimarca, 14/14 20093 Cologno Monzese - Milano - ITALY
	DATA	16/05/2017	SCALA	1:3	AGGIORNAMENTO STRUTTURA		Rev	Visto	
MODIFICHE								SPAREPARTS G2C250ac MOTOR CODE 30775NT 24 Vdc / 1500 W WHEEL ϕ 260x101 POLYURETHANE 92Sh Project Nr. -	CODICE 10232NTGH-E
0	EMISSIONE				16.05.17	ANZ			
2	MODIFICATO FORMATO A2 (Ero A3)				09.04.21	PD			