

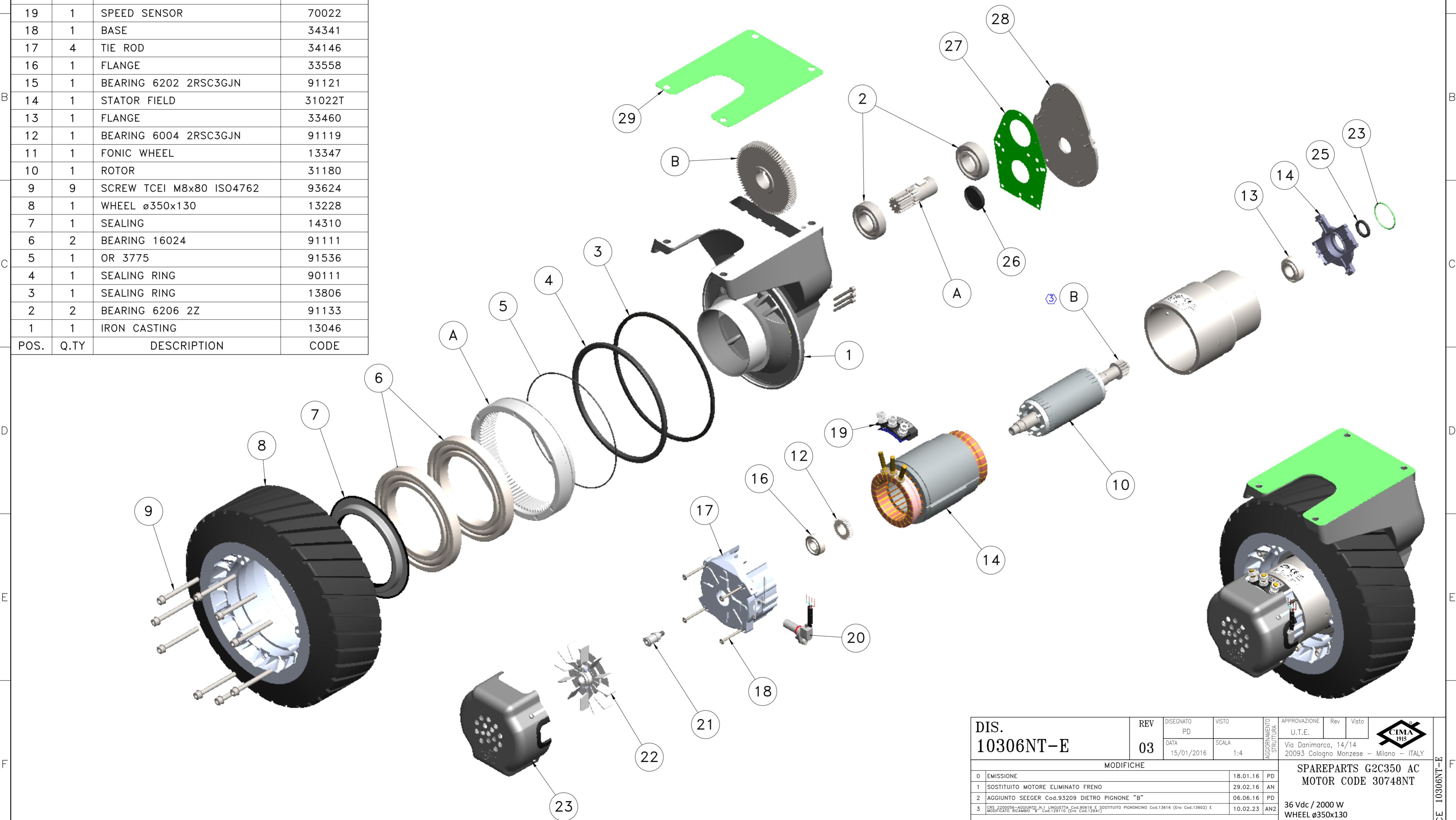

POS.	Q.TY	DESCRIPTION	CODE
28	1	GASKET	13911
27	1	PLATE	13724
26	1	SEAL PLATE	13920
25	1	CAP	14016
24	1	SEALING	90118
23	1	OR 3168	91554
22	1	COVER	33743
21	1	FAN	33824
20	1	REDUCTION	33208
19	1	SPEED SENSOR	70022
18	1	BASE	34341
17	4	TIE ROD	34146
16	1	FLANGE	33558
15	1	BEARING 6202 2RSC3GJN	91121
14	1	STATOR FIELD	31022T
13	1	FLANGE	33460
12	1	BEARING 6004 2RSC3GJN	91119
11	1	FONIC WHEEL	13347
10	1	ROTOR	31180
9	9	SCREW TCEI M8x80 ISO4762	93624
8	1	WHEEL ø350x130	13228
7	1	SEALING	14310
6	2	BEARING 16024	91111
5	1	OR 3775	91536
4	1	SEALING RING	90111
3	1	SEALING RING	13806
2	2	BEARING 6206 2Z	91133
1	1	IRON CASTING	13046

B	GEARS	129110	③
A	GEARS	12988	

B	GEARS	12941
A	GEARS	12988
ONLY ONE TAB		



DIS. <b>10306NT-E</b>	REV	03	DESEGNATO	PD	VISTO	U.T.E.	APPROVAZIONE	Rev	Visto	 Via Danimarca, 14/14 20093 Cologno Monzese - Milano - ITALY
	DATA	15/01/2016	SCALA	1:4	AGGIORNAMENTO STRUTTURA					
MODIFICHE										
0	EMMISSIONE								18.01.16	PD
1	SOSTITUITO MOTORE ELIMINATO FRENO								29.02.16	AN
2	AGGIUNTO SEEGER Cod.93209 DIETRO PIGNONE "B"								06.06.16	PD
3	CBS 2200056-AGGIUNTO N.1 LINGUETTA Cod.90619, E SOSTITUITO PIGNONCINO Cod.13616 (Era Cod.13602) E MODIFICATO RICAMBIO "B" Cod.129110 (Era Cod.12941)								10.02.23	AN2
SPAREPARTS G2C350 AC MOTOR CODE 30748NT										
36 Vdc / 2000 W WHEEL ø350x130 RUBBER BLACK 70ø72 Sh										
Project Nr. 1463										

Formato: A2 Disegno eseguito con SW non sono ammesse variazioni o modifiche manuali  
 CODICE 10306NT-E