

POS.	Q.TY	DESCRIPTION	CODE
27	1	GASKET	13902
26	1	BRAKE $\varnothing$ 84SR	11104
25	1	BRAKE PLATE	13716
24	1	BRAKE PLATE SEAL	13912
23	1	SEALING	90117
22	1	SEALING	90123
21	1	OR 3168	91528
20	1	COVER	35122
19	1	TIE ROD M6	34124
18	1	TIE ROD M6	34105
17	4	BRUSH	33616
16	1	FLANGE	31885
15	1	BASE	34344
14	1	CONNECTION	32059
13	1	CONNECTION	32061
12	1	FLANGE	33461
11	1	BEARING 6201 2RSC3GJN	91120
10	1	BEARING 6004 2RSC3GJN	91119
9	1	ARMATURE	31294
8	10	SCREW TCEI M5x34	93642
7	1	WHEEL $\varnothing$ 250x76	132220
6	1	SEALING	14310
5	1	BEARING 16024	91111
4	1	O-RING OR3725	91534
3	1	SEALING RING	90115
2	2	BEARING 6006 2Z	91110
1	1	AL CASTING	13054

C	FERODO	12914
B	GEARS	12903
A	GEARS	12946

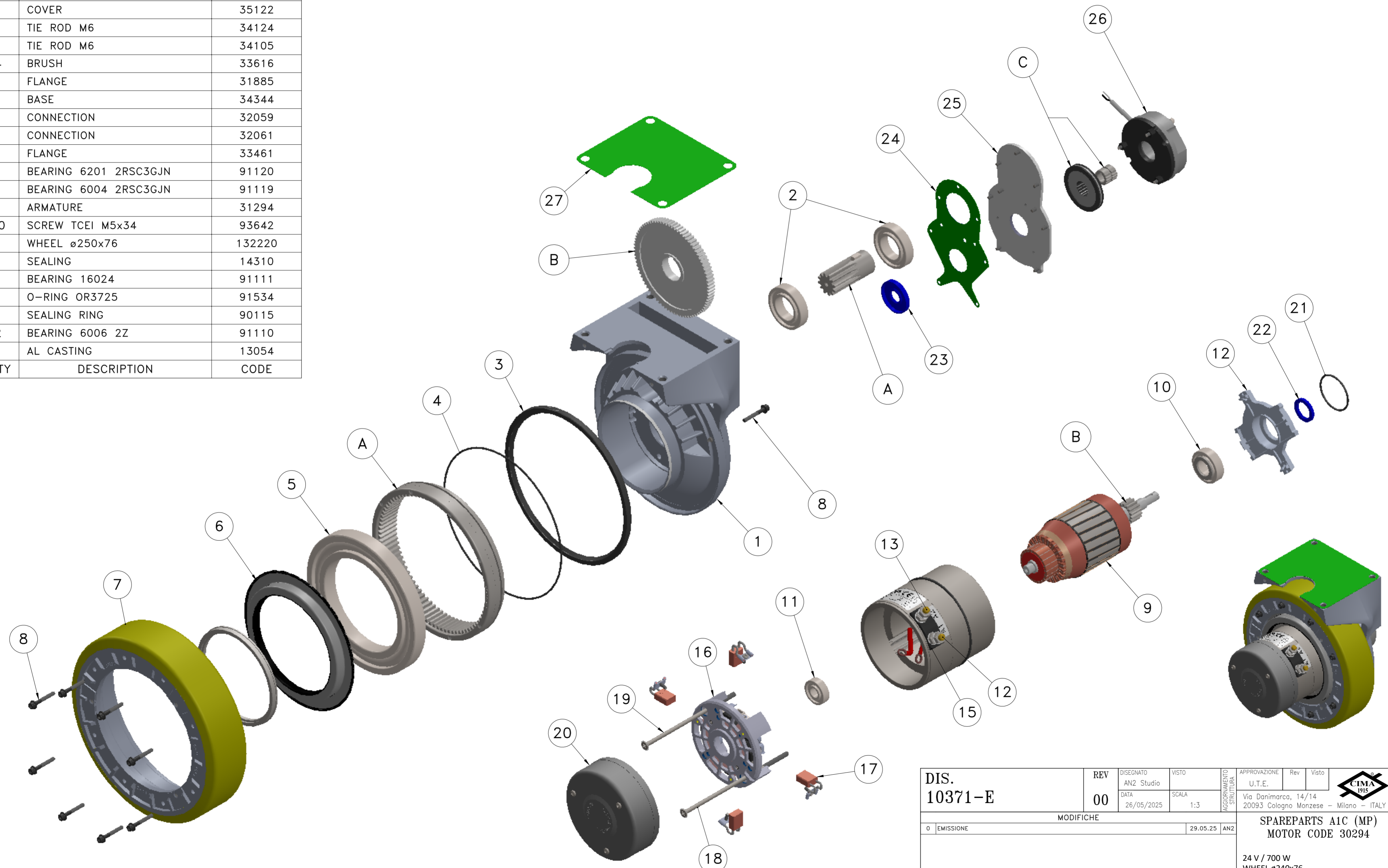

DIS. 10371-E	REV	00	DISEGNATO	AN2 Studio	VISTO		APPROVAZIONE	U.T.E.	
	DATA	26/05/2025	SCALA	1:3	AGGIORNAMENTO STRUTTURA		Via Danimarca, 14/14 20093 Cologno Monzese - Milano - ITALY		
MODIFICHE							29.05.25	AN2	<b>SPAREPARTS A1C (MP)</b> <b>MOTOR CODE 30294</b>  24 V / 700 W WHEEL $\varnothing$ 240x76 POLIURETHANE 80Sh Project Nr. 2500041/000
0 EMISSIONE									

CODICE 10371-E