

POS.	Q.TY	DESCRIPTION	CODE
28	1	GASKET	13911
27	1	PLATE	13724
26	1	SEAL PLATE	13920
25	1	CAP	14016
24	1	SEALING	90123
23	1	OR 3168	91554
22	1	COVER	33743
21	1	FAN	33824
20	1	REDUCTION	33208
19	1	SPEED SENSOR	70022
18	1	BASE	34341
17	4	TIE ROD	34146
16	1	FLANGE	33558
15	1	BEARING 6202 2RSC3GJN	91121
14	1	STATOR FIELD	31058T
13	1	FLANGE	33460
12	1	BEARING 6004 2RSC3GJN	91119
11	1	FONIC WHEEL	13347
10	1	ROTOR	31180
9	9	SCREW TCEI M8x80 ISO4762	93624
8	1	WHEEL ø350x130	13228
7	1	SEALING	14310
6	2	BEARING 16024	91111
5	1	OR 3775	91536
4	1	SEALING RING	90111
3	1	SEALING RING	13806
2	2	BEARING 6206 2Z	91133
1	1	IRON CASTING	13046

B	GEARS	129110
A	GEARS	12988

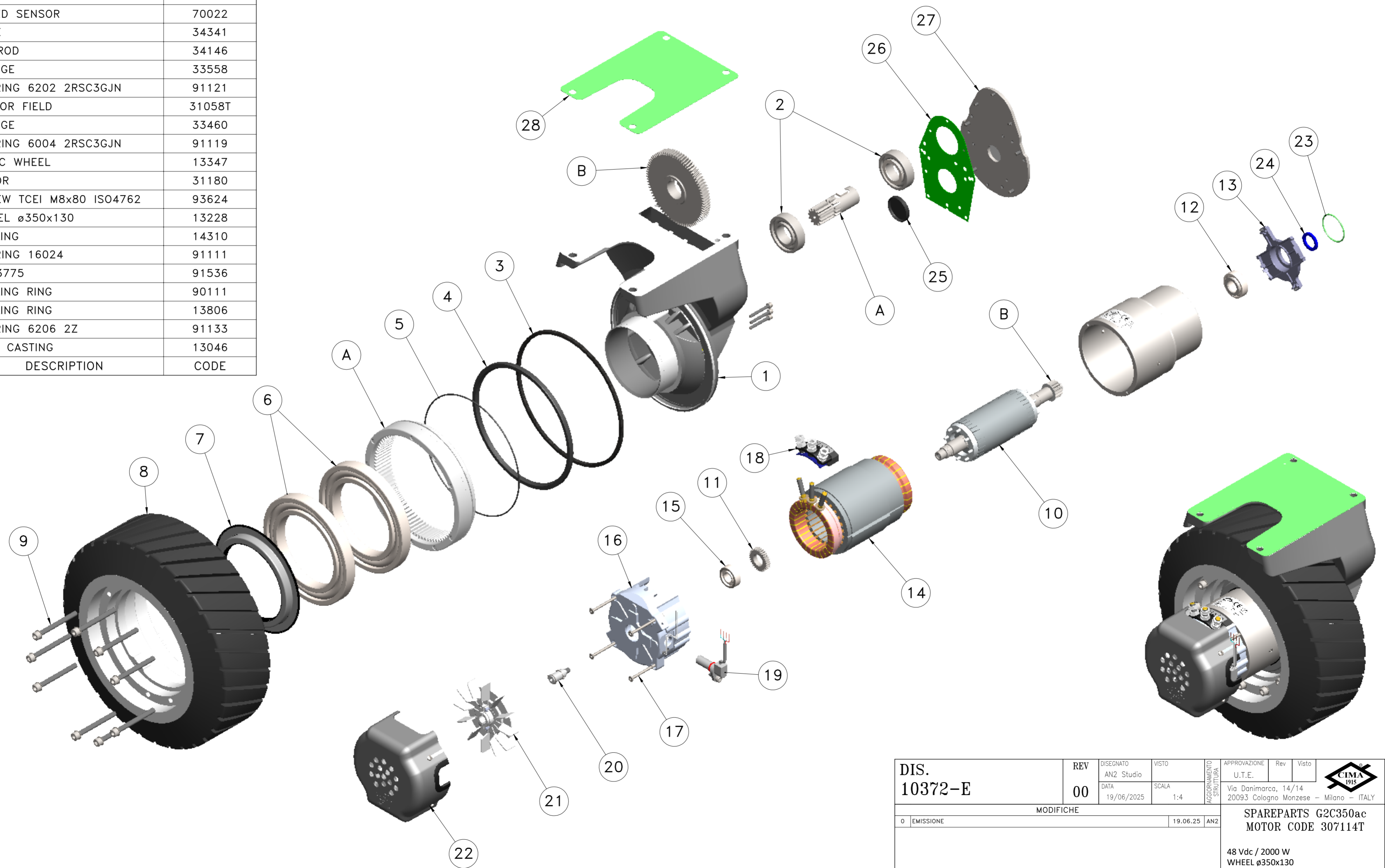

DIS. 10372-E	REV	00	DISEGNATO	AN2 Studio	VISTO		APPROVAZIONE	U.T.E.	Rev	Visto			
	DATA	19/06/2025	SCALA	1:4	AGGIORNAMENTO STRUTTURA		Via Danimarca, 14/14 20093 Cologno Monzese - Milano - ITALY						
MODIFICHE												<b>SPAREPARTS G2C350ac</b> <b>MOTOR CODE 307114T</b>  48 Vdc / 2000 W WHEEL ø350x130 RUBBER BLACK 70±72 Sh Project Nr. 2500043/000	<b>CODICE 10372-E</b>
0 EMISSIONE													