

POS.	Q.TY	DESCRIPTION	CODE
29	1	GASKET	13911
28	1	BRAKE ϕ 124CR	11125
27	1	PLATE	13724
26	1	SEAL PLATE	13920
25	2	SEALING	90117
24	1	SEALING	90123
23	1	OR 3168	91554
22	1	COVER	33743
21	1	FAN	33824
20	1	REDUCTION	33208
19	1	SPEED SENSOR	70022
18	1	BASE	34341
17	4	TIE ROD	34146
16	1	FLANGE	33558
15	1	BEARING 6202 2RSC3GJN	91121
14	1	STATOR FIELD	31030T
13	1	FLANGE	33460
12	1	BEARING 6004 2RSC3GJN	91119
11	1	FONIC WHEEL	13347
10	1	ROTOR	31156
9	9	SCREW TCEI M8 ISO 4762	93624
8	1	WHEEL ϕ 350x130	13228
7	1	SEALING	14310
6	2	BEARING 16024	91111
5	1	OR 3775	91536
4	1	SEALING RING	90111
3	1	SEALING RING	13806
2	2	BEARING 6206 2Z	91133
1	1	IRON CASTING	13046

C	FERODO	12916
B	GEARS	12941
A	GEARS	12988

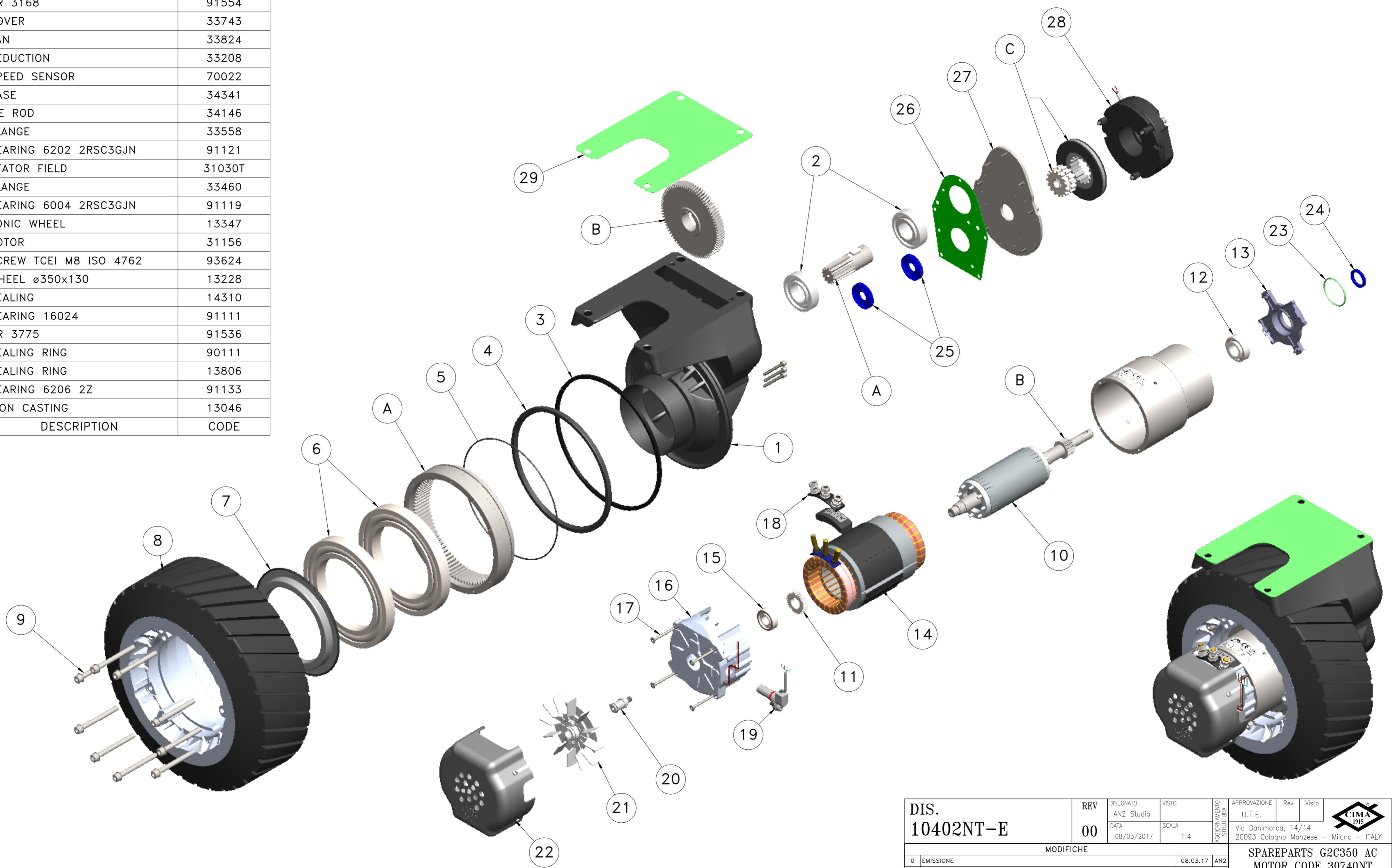

DIS. 10402NT-E	REV	00	DISegnATO	AN2 Studio	VISTO		APPROVAZIONE	U.T.E.	 Via Danimarca, 14/14 20093 Cologno Monzese - Milano - ITALY
	DATA	08/03/2017	SCALA	1:4	AGGIORNAMENTO STRUTTURA		Rev	Visto	
MODIFICHE							08.03.17	ANZ	SPAREPARTS G2C350 AC MOTOR CODE 30740NT 24 Vcc / 2000 W WHEEL ϕ 350x130 BLACK RUBBER TRACED
0 EMISSIONE									

Formato: A2 Disegno eseguito con SW non sono ammesse variazioni o modifiche manuali
 CODICE 10402NT-E