

POS.	Q.TY	DESCRIPTION	CODE
28	1	GASKET	13902
27	1	BRAKE $\varnothing$ 104CR	11117
26	1	FILTER PROTECTION	14410
25	1	OR 2225	91556
24	1	COVER	14104
23	2	SEALING	90117
22	6	SCREW TCEI M5x34	93642
21	1	SEALING	90123
20	1	OR 3168	91554
19	1	SPEED SENSOR	70022
18	4	TIE ROD	34146
17	1	FLANGE	33548
16	1	BEARING 6202 2RSC3GJN	91121
15	1	BASE	34341
14	1	STATOR FIELD	31009T
13	1	FLANGE	33460
12	1	BEARING 6004 2RSC3GJN	91119
11	1	FONIC WHEEL	13347
10	1	ROTOR	31129
9	9	SCREW TCEI M8x54	93637
8	1	WHEEL WITHOUT BANDAGE	132173
7	1	SEALING	14310
6	2	BEARING 16024	91111
5	1	OR 3775	91536
4	1	SEALING RING	90115
3	2	COMPENSATION RING	92702
2	2	BEARING 6206 2Z	91133
1	1	IRON CASTING	13040

C	FERODO	12913
B	GEARS	12903
A	GEARS	12943

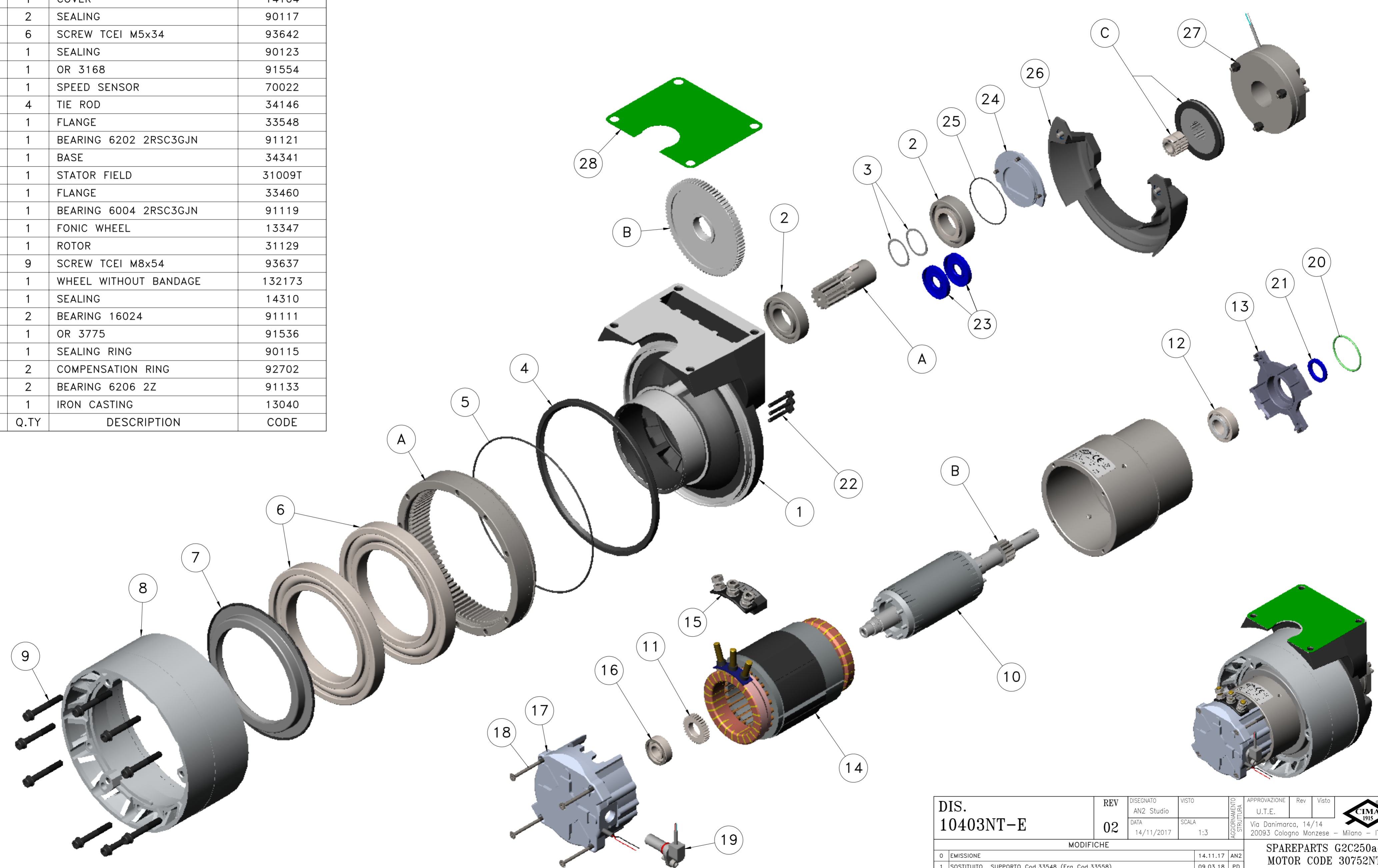

DIS. 10403NT-E	REV	02	DISEGNATO	AN2 Studio	VISTO		APPROVAZIONE	U.T.E.	
	DATA	14/11/2017	SCALA	1:3	AGGIORNAMENTO STRUTTURA		Via Danimarca, 14/14 20093 Cologno Monzese - Milano - ITALY		
MODIFICHE								<b>SPAREPARTS G2C250ac</b> <b>MOTOR CODE 30752NT</b>  24 Vdc / 1700 W WHEEL $\varnothing$ 216x101 WITHOUT BANDAGE  Project Nr. -	<b>CODICE 10403NT-E</b>
0	EMISSIONE		14.11.17	ANZ					
1	SOSTITUITO SUPPORTO Cod.33548 (Era Cod.33558)		09.03.18	PD					
2	MODIFICATO FORMATO A2 (Era A3)		09.04.21	PD					