

1	2	3	
30	1	GASKET	13908
29	1	BRAKE PLATE	13731
28	1	GASKET BRAKE PLATE	13923
27	1	CAP	14016
26	6	SCREW TCEI M5x34	93642
25	1	SEALING	90123
24	1	OR 3168	91554
23	1	COVER	35136
22	1	FAN	33826
21	4	BRUSH	33620
20	1	FLANGE	31854
19	1	BEARING 6201 2RSC3GJN	91120
18	2	BASE	34345
17	1	CONNECTION	32059
16	1	CONNECTION	32060
15	2	TERMINAL	34002
14	1	FIELD	315161
13	1	FLANGE	33460
12	1	BEARING 6004 2RSC3GJN	91119
11	1	ARMATURE	31397
10	9	SCREW TCEI M8x54	93637
9	1	WHEEL ø300x101	132101
8	1	SEALING	14310
7	2	BEARING 16024	91111
6	1	OR 3775	91536
5	1	SEALING RING	90111
4	1	SEALING RING	13806
3	2	COMPENSATION RING	92702
2	2	BEARING 6206 2Z	91133
1	1	IRON CASTING	13039
POS.	Q.TY	DESCRIPTION	CODE

4	5	6	
31A	1	PROTECTION	14415
29A	1	COVER	14104
28A	1	OR 2225	91556
2A	3	BEARING 16006	91109
1A	1	IRON CASTING	13039-OLD
POS.	Q.TY	DESCRIPTION OLD ASSEMBLY	CODE

7	8	
B	GEARS	12941
A	GEARS	12945

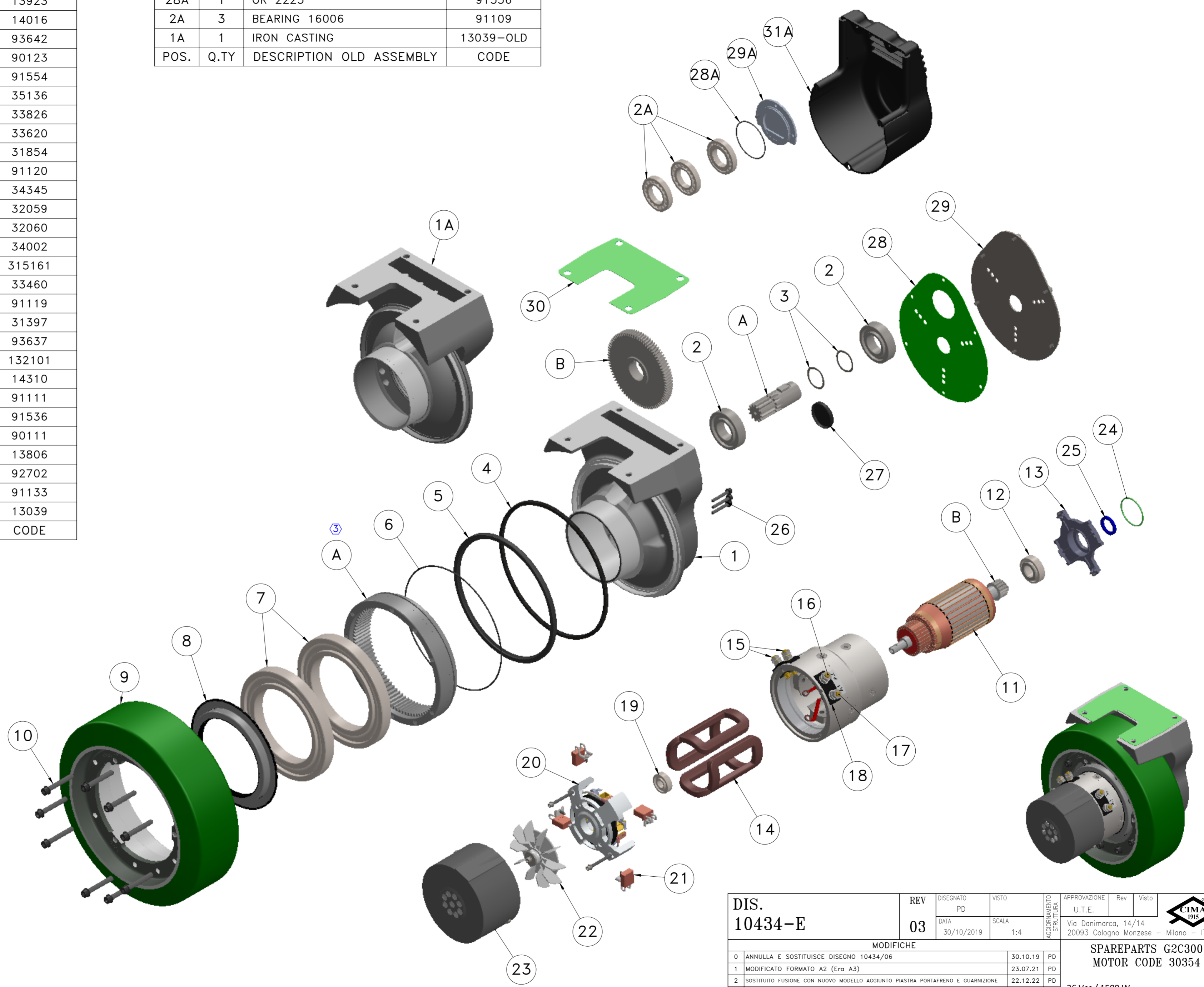

DIS. 10434-E	REV	03	DESIGNATO	PD	VISTO		APPROVAZIONE	Rev	Visto	
	DATA	30/10/2019	SCALA	1:4	AGGIORNAMENTO STRUTTURA		U.T.E.			
MODIFICHE 0 ANNULLA E SOSTITUISCE DISEGNO 10434/06 30.10.19 PD 1 MODIFICATO FORMATO A2 (Era A3) 23.07.21 PD 2 SOSTITUITO FUSIONE CON NUOVO MODELLO AGGIUNTO PIASTRA PORTAFRENO E GUARNIZIONE 22.12.22 PD 3 CRS 2400013-SOSTITUITO CORONA+PIGNONE Cod.12945 (Era Cod.12942) 09.01.26 FB										
							Via Danimarca, 14/14 20093 Cologno Monzese - Milano - ITALY <b>SPAREPARTS G2C300</b> <b>MOTOR CODE 30354</b> 36 Vcc / 1500 W WHEEL ø300x101 POLIURETHANE GREEN ABRADED 75 Sh.			
							Project Nr.			

Formato: A2 - Disegno eseguito con SW non sono ammesse variazioni o modifiche manuali  
 CODICE 10434-E