

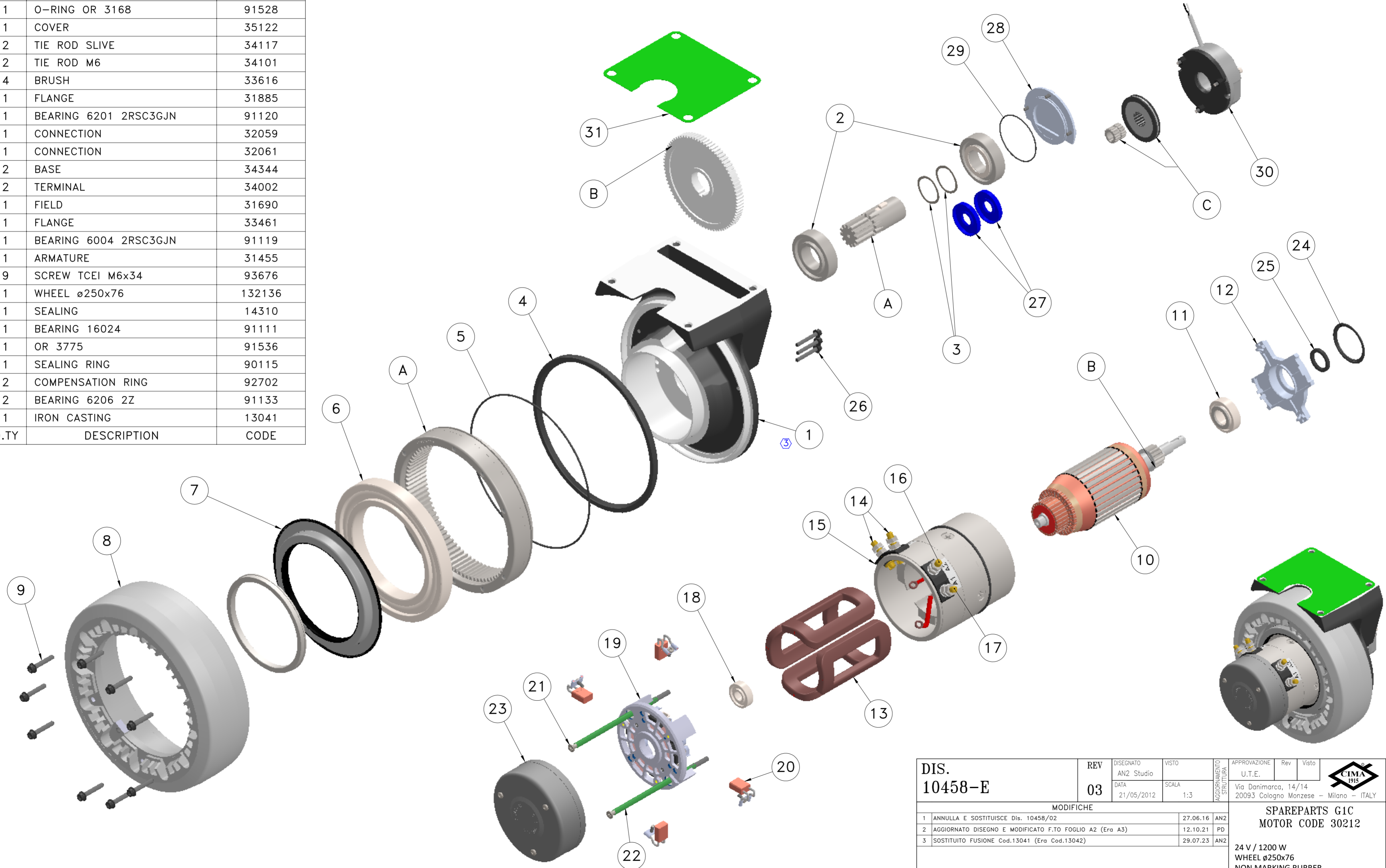

POS.	Q.TY	DESCRIPTION	CODE
31	1	GASKET	13902
30	1	BRAKE \varnothing 84SR	11104
29	1	OR 2225	91556
28	1	COVER	14104
27	2	SEALING	90117
26	6	SCREW TCEI M5x34	93642
25	1	SEALING	90118
24	1	O-RING OR 3168	91528
23	1	COVER	35122
22	2	TIE ROD SLIVE	34117
21	2	TIE ROD M6	34101
20	4	BRUSH	33616
19	1	FLANGE	31885
18	1	BEARING 6201 2RSC3GJN	91120
17	1	CONNECTION	32059
16	1	CONNECTION	32061
15	2	BASE	34344
14	2	TERMINAL	34002
13	1	FIELD	31690
12	1	FLANGE	33461
11	1	BEARING 6004 2RSC3GJN	91119
10	1	ARMATURE	31455
9	9	SCREW TCEI M6x34	93676
8	1	WHEEL \varnothing 250x76	132136
7	1	SEALING	14310
6	1	BEARING 16024	91111
5	1	OR 3775	91536
4	1	SEALING RING	90115
3	2	COMPENSATION RING	92702
2	2	BEARING 6206 2Z	91133
1	1	IRON CASTING	13041

C	FERODO	12914
B	GEARS	12903
A	GEARS	12944



DIS. 10458-E	REV	03	DISEGNATO	AN2 Studio	VISTO		APPROVAZIONE	U.T.E.	 Via Danimarca, 14/14 20093 Cologno Monzese - Milano - ITALY
	DATA	21/05/2012	SCALA	1:3	AGGIORNAMENTO				
	MODIFICHE								
1		ANNULLA E SOSTITUISCE Dis. 10458/02			27.06.16	AN2	SPAREPARTS G1C MOTOR CODE 30212 24 V / 1200 W WHEEL \varnothing 250x76 NON MARKING RUBBER		
2		AGGIORNATO DISEGNO E MODIFICATO F.TO FOGLIO A2 (Era A3)			12.10.21	PD			
3		SOSTITUITO FUSIONE Cod.13041 (Era Cod.13042)			29.07.23	AN2			
Project Nr.		-							

Formato: A2 - Disegno eseguito con SW non sono ammesse variazioni o modifiche manuali
 CODICE 10458-E