

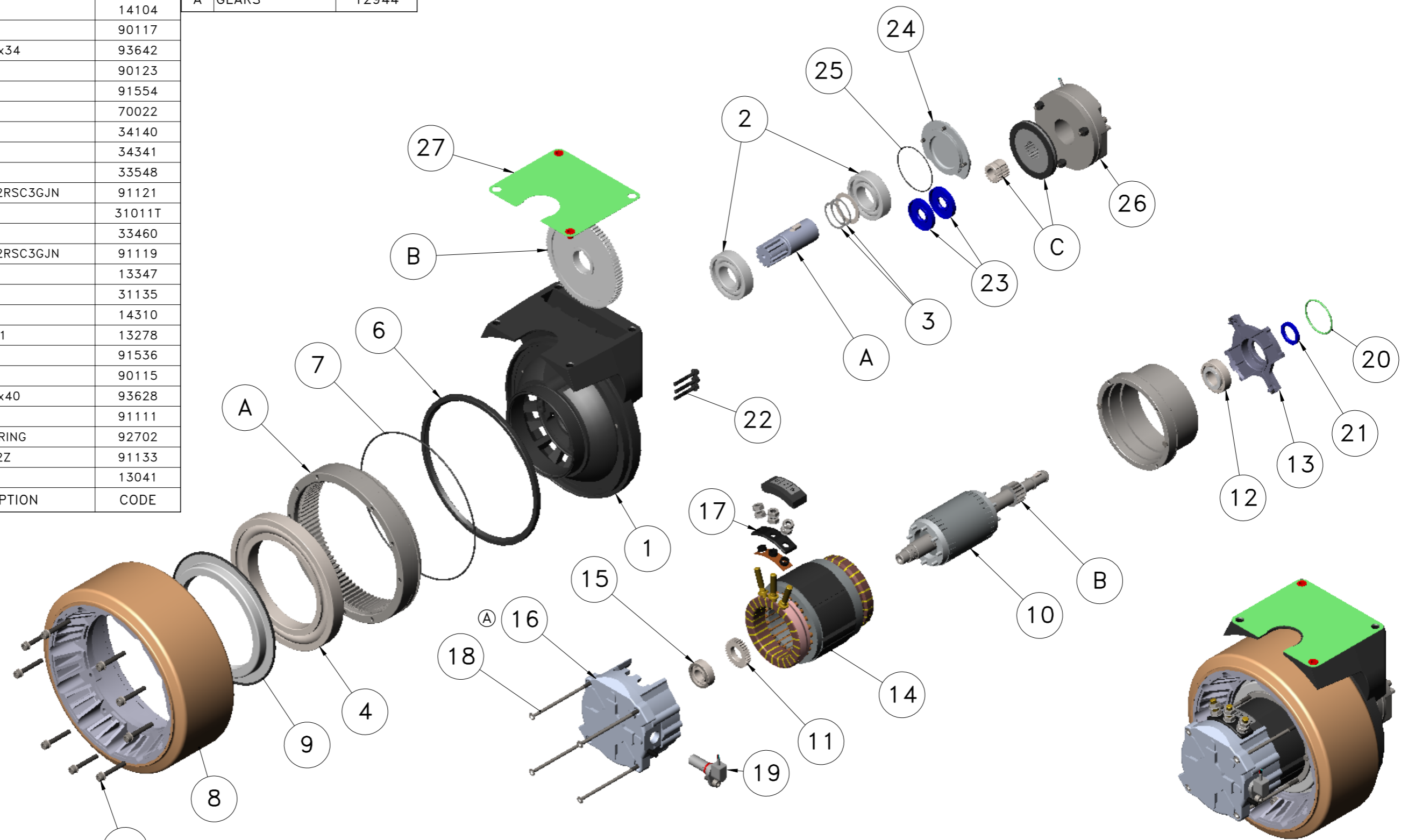

POS.	Q.TY	DESCRIPTION	CODE
27	1	GASKET	13902
26	1	BRAKE ø104CR	11117
25	1	OR 2225	91556
24	1	COVER	14104
23	2	SEALING	90117
22	6	SCREW TCEI M5x34	93642
21	1	SEALING	90123
20	1	OR 3168	91554
19	1	SPEED SENSOR	70022
18	4	TIE ROD M5	34140
17	1	BASE	34341
16	1	FLANGE	33548
15	1	BEARING 6202 2RSC3GJN	91121
14	1	STATOR FIELD	31011T
13	1	FLANGE	33460
12	1	BEARING 6004 2RSC3GJN	91119
11	1	FONIC WHEEL	13347
10	1	ROTOR	31135
9	1	SEALING	14310
8	1	WHEEL ø250x101	13278
7	1	OR 3775	91536
6	1	SEALING RING	90115
5	9	SCREW TCEI M6x40	93628
4	1	BEARING 16024	91111
3	2	COMPENSATION RING	92702
2	2	BEARING 6206 2Z	91133
1	1	IRON CASTING	13041

C	FERODO	12913
B	GEARS	12903
A	GEARS	12944



DIS. 10472NT-E		REV 01	DISEGNATO	VISTO	APPROVAZIONE U.T.E.	Rev	Visto	 Via Danimarca, 14/14 20093 Cologno Monzese - Milano - ITALY
MODIFICHE			DATA 04/10/2012	SCALA 1:5	AGGIORNAMENTO STRUTTURA			
0	EMISSIONE					30.05.16	AN2	<b>SPAREPARTS G1C AC</b> <b>MOTOR CODE 30751NT</b>  24 Vcc / 1200 W WHEEL ø250x101 RUBBER
A	SOSTITUITO SUPPORTO Cod.33548 (ERA Cod.35558)					09.03.18	PD	
						Project Nr.		<b>CODICE 10472NT-E</b>

S:\ArchivioDirectory\Nuove\ArchivioDocumentazione\CLIENTI\ESPLOSI RICAMBI\Motoruote Ghisa\

Formato: A3 Disegno eseguito con SW non sono ammesse variazioni o modifiche manuali