

| POS. | Q.TY | DESCRIPTION | CODE |
|------|------|-----------------------|--------|
| 27 | 1 | BRAKE ø104CR | 11117 |
| 26 | 1 | GASKET | 13902 |
| 25 | 1 | OR 2225 | 91556 |
| 24 | 1 | COVER | 14104 |
| 23 | 2 | SEALING | 90117 |
| 22 | 6 | SCREW TCEI M5x34 | 93642 |
| 21 | 1 | FLANGE | 33548 |
| 20 | 1 | SEALING | 90123 |
| 19 | 1 | OR 3168 | 91554 |
| 18 | 1 | SPEED SENSOR | 70022 |
| 17 | 4 | TIE ROD M5 | 34140 |
| 16 | 1 | BASE | 34341 |
| 15 | 1 | BEARING 6202 2RSC3GJN | 91121 |
| 14 | 1 | STATOR FIELD | 31011T |
| 13 | 1 | FLANGE | 33460 |
| 12 | 1 | BEARING 6004 2RSC3GJN | 91119 |
| 11 | 1 | FONIC WHEEL | 13347 |
| 10 | 1 | ROTOR | 31135 |
| 9 | 2 | COMPENSATION RING | 92702 |
| 8 | 9 | SCREW TCEI M6x40 | 93628 |
| 7 | 1 | WHEEL ø245x101 | 13277 |
| 6 | 1 | SEALING | 14310 |
| 5 | 1 | OR 3775 | 91536 |
| 4 | 2 | BEARING 6206 2Z | 91133 |
| 3 | 1 | SEALING RING | 90115 |
| 2 | 1 | BEARING 16024 | 91111 |
| 1 | 1 | IRON CASTING | 13041 |

| | | |
|---|--------|-------|
| C | FERODO | 12913 |
| B | GEARS | 12903 |
| A | GEARS | 12944 |

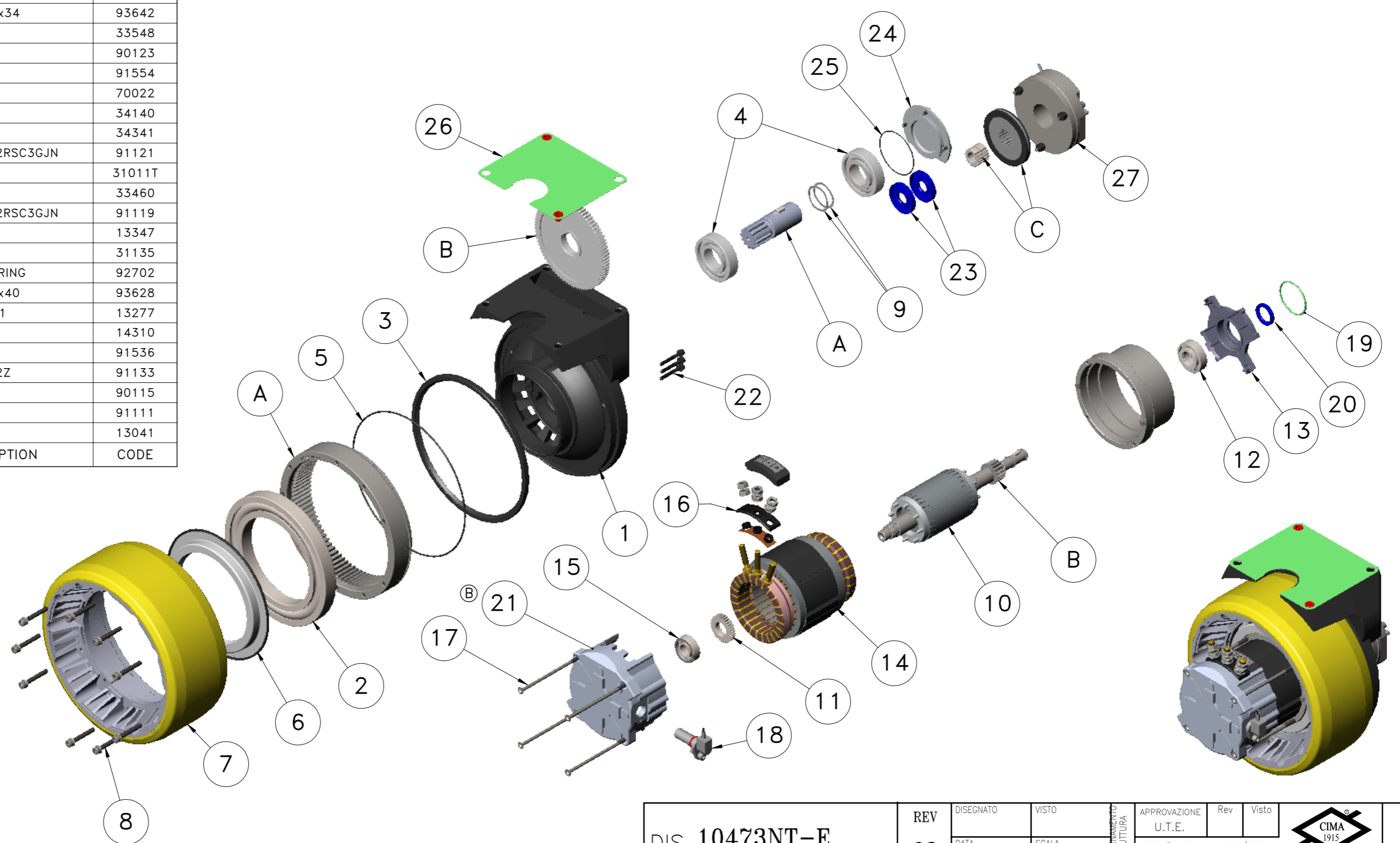

| | | | | | | | |
|----------------|---|--------|-----------------|-----------|--|-----|-------|
| DIS. 10473NT-E | | REV 02 | DISEGNATO | VISTO | APPROVAZIONE U.T.E. | Rev | Visto |
| | | | DATA 04/10/2012 | SCALA 1:5 | Via Danimarca, 14/14 20093 Cologno Monzese - Milano - ITALY | | |
| MODIFICHE | | | | | | | |
| O | EMISSIONE | | 04.10.12 | AN | SPAREPARTS G1C AC MOTOR CODE 30751NT 24 Vcc / 1200 W WHEEL ø245x101 POLYURETHANE | | |
| A | AGGIORNATO | | 20.02.14 | AN | | | |
| B | SOSTITUITO SUPPORTO Cod.33548 (ERA Cod.35558) | | 09.03.18 | PD | | | |
| | | | | | Project Nr. | | |

S:\ArchivioDirectory\Nuove\ArchivioDocumentazione\CLIENTI\ESPLOSI RICAMBI\Motoruote Ghisa\

Disegno eseguito con SW non sono ammesse variazioni o modifiche manuali

CODICE 10473NT-E