

POS.	Q.TY	DESCRIPTION	CODE
28	1	GASKET	13902
27	1	BRAKE ϕ 104CR	11117
26	1	FILTER PROTECTION	14410
25	1	OR 2225	91556
24	1	COVER	14104
23	2	SEALING	90117
22	6	SCREW TCEI M5x34	93642
21	1	SEALING	90123
20	1	OR 3168	91554
19	1	SPEED SENSOR	70022
18	1	BASE	34341
17	4	TIE ROD	34146
16	1	FLANGE	33557
15	1	BEARING 6202 2RSC3GJN	91121
14	1	STATOR FIELD	31009T
13	1	FLANGE	33460
12	1	BEARING 6004 2RSC3GJN	91119
11	1	FONIC WHEEL	13347
10	1	ROTOR	31129
9	9	SCREW TCEI M8x54	93637
8	1	WHEEL ϕ 245x101	13281
7	1	SEALING	14310
6	2	BEARING 16024	91111
5	1	OR 3775	91536
4	1	SEALING RING	90115
3	2	COMPENSATION RING	92702
2	2	BEARING 6206 2Z	91133
1	1	IRON CASTING	13040

C	FERODO	12913
B	GEARS	12931
A	GEARS	12943

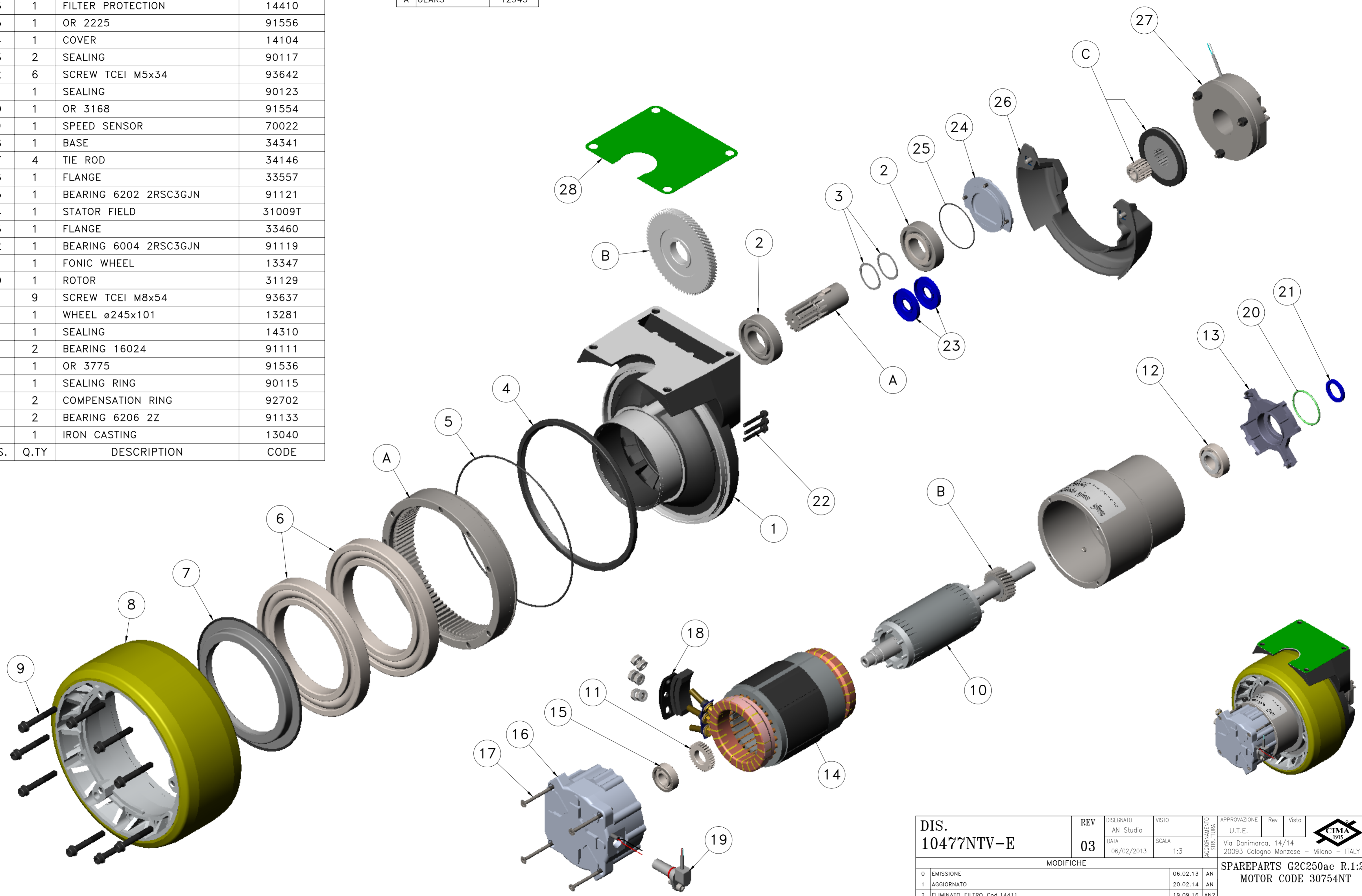

DIS. 10477NTV-E	REV 03	DISEGNATO AN Studio	VISTO	APPROVAZIONE U.T.E.	
		DATA 06/02/2013	SCALA 1:3	Via Danimarca, 14/14 20093 Cologno Monzese - Milano - ITALY	
MODIFICHE					
0	EMISSIONE		06.02.13	AN	SPAREPARTS G2C250ac R.1:20 MOTOR CODE 30754NT 24 Vdc / 1700 W WHEEL ϕ 245x101 POLYURETHANE 92Sh Project Nr. -
1	AGGIORNATO		20.02.14	AN	
2	ELIMINATO FILTRO Cod.14411		19.09.16	AN2	
3	MODIFICATO FORMATO A2 (Era A3)		09.04.21	PD	

CODICE 10477NTV-E
 Disegno eseguito con SW non sono ammesse variazioni o modifiche manuali
 Formato: A2