

POS.	Q.TY	DESCRIPTION	CODE
26	1	GASKET	13902
25	1	BRAKE \varnothing 104CR	11117
24	1	FILTER PROTECTION	14410
23	1	OR 2225	91556
22	1	COVER	14104
21	2	SEALING	90117
20	6	SCREW TCEI M5x34	93642
19	1	SEALING	90123
18	1	OR 3168	91554
17	4	TIE ROD	34146
16	1	FLANGE	33548
15	1	BEARING BMB 6202	91138
14	1	BASE	34341
13	1	STATOR FIELD	31003T
12	1	FLANGE	33460
11	1	BEARING 6004 2RSC3GJN	91119
10	1	ROTOR	31129
9	9	SCREW TCEI M8x54	93637
8	1	WHEEL \varnothing 268x101	132102
7	1	SEALING	14310
6	2	BEARING 16024	91111
5	1	OR 3775	91536
4	1	SEALING RING	90115
3	2	COMPENSATION RING	92702
2	2	BEARING 6206 2Z	91133
1	1	IRON CASTING	13040

C	FERODO	12913
B	GEARS	12903
A	GEARS	12943

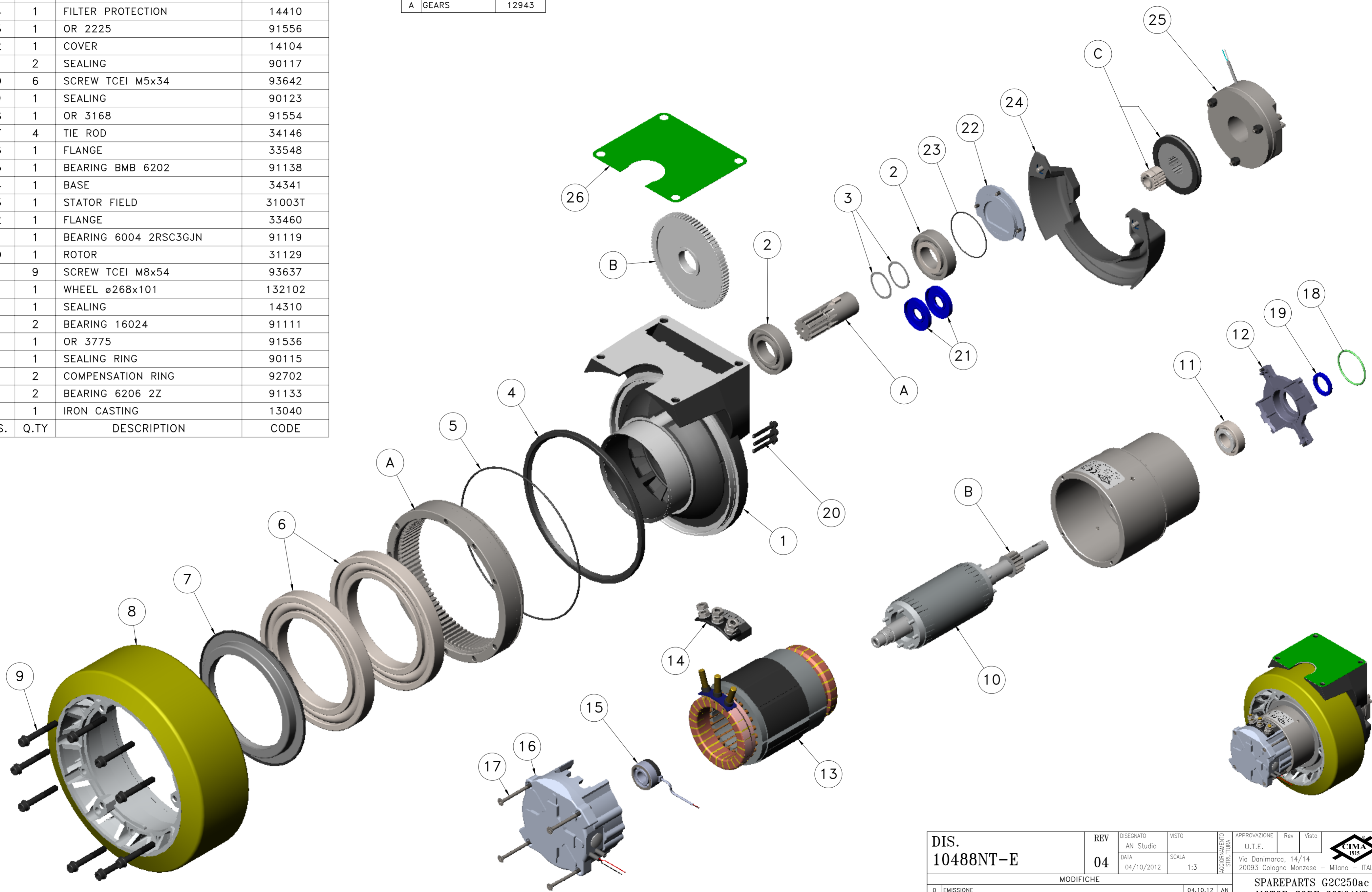

DIS. 10488NT-E	REV	DISEGNATO	VISTO	APPROVAZIONE	Rev	Visto	
	04	AN Studio	SCALA	U.T.E.			
		DATA	1:3	Via Danimarca, 14/14 20093 Cologno Monzese - Milano - ITALY			
		MODIFICHE					
0		EMISSIONE	04.10.12	AN	SPAREPARTS G2C250ac MOTOR CODE 30764NT 24 Vcc / 2000 W WHEEL \varnothing 268x101 POLYURETHANE		
1		AGGIORNATO	20.02.14	AN			
2		ELIMINATO FILTRO Cod.14411	19.09.16	AN2			
3		MODIFICATO FORMATO A2 (Era A3)	09.04.21	PD	Project Nr. -		