

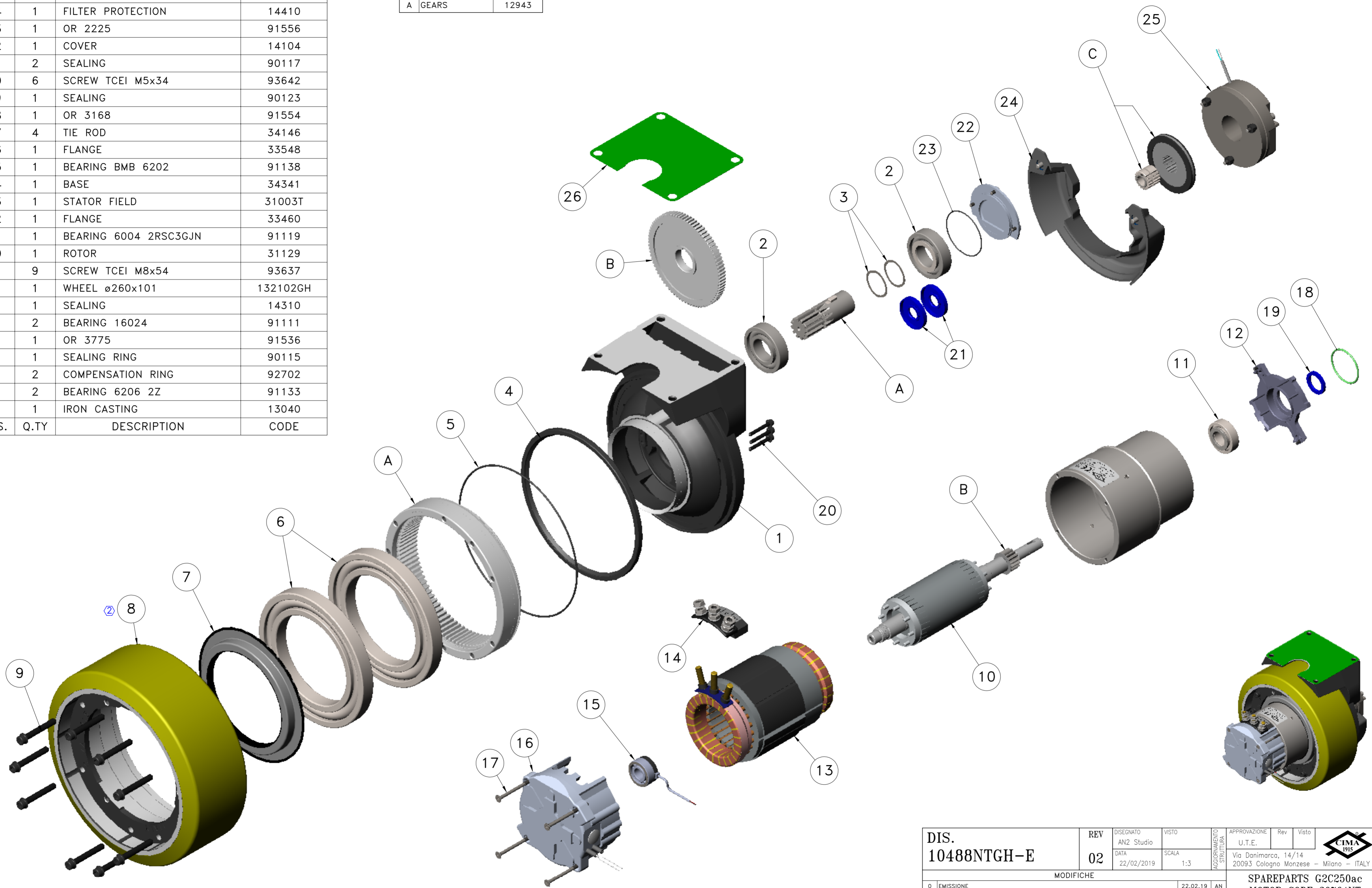

POS.	Q.TY	DESCRIPTION	CODE
26	1	GASKET	13902
25	1	BRAKE \varnothing 104CR	11117
24	1	FILTER PROTECTION	14410
23	1	OR 2225	91556
22	1	COVER	14104
21	2	SEALING	90117
20	6	SCREW TCEI M5x34	93642
19	1	SEALING	90123
18	1	OR 3168	91554
17	4	TIE ROD	34146
16	1	FLANGE	33548
15	1	BEARING BMB 6202	91138
14	1	BASE	34341
13	1	STATOR FIELD	31003T
12	1	FLANGE	33460
11	1	BEARING 6004 2RSC3GJN	91119
10	1	ROTOR	31129
9	9	SCREW TCEI M8x54	93637
8	1	WHEEL \varnothing 260x101	132102GH
7	1	SEALING	14310
6	2	BEARING 16024	91111
5	1	OR 3775	91536
4	1	SEALING RING	90115
3	2	COMPENSATION RING	92702
2	2	BEARING 6206 2Z	91133
1	1	IRON CASTING	13040

C	FERODO	12913
B	GEARS	12903
A	GEARS	12943



DIS. 10488NTGH-E	REV	02	DISEGNATO	AN2 Studio	VISTO	AN	APPROVAZIONE	U.T.E.	 Via Danimarca, 14/14 20093 Cologno Monzese - Milano - ITALY
	DATA	22/02/2019	SCALA	1:3	AGGIORNAMENTO STRUTTURA	AN	Rev	Visto	
MODIFICHE							22.02.19	AN	SPAREPARTS G2C250ac MOTOR CODE 30764NT 24 Vdc / 2000 W WHEEL \varnothing 268x101 POLYURETHANE 92Sh Project Nr. 1900020
0	EMISSIONE						22.02.19	AN	
1	MODIFICATO FORMATO A2 (Era A3)						09.04.21	PD	
2	CRM 2300046--SOSTITUITO RUOTA Cod.132102GH (Era Cod.13211GH)						18.07.23	AN2	