

POS.	Q.TY	DESCRIPTION	CODE
30	1	GASKET	13902
29	1	BRAKE \varnothing 104CR	11117
28	1	OR 2225	91556
27	1	COVER	14104
26	2	SEALING	90117
25	1	OR 3168	91554
24	1	SEALING	90118
23	1	COVER	35121
22	2	TIE ROD SLIVE	34117
21	2	TIE ROD M6	34103
20	4	BRUSH	33616
19	1	FLANGE	31885
18	2	BASE	34344
17	1	CONNECTION	32059
16	1	CONNECTION	32061
15	2	TERMINAL	34002
14	1	FIELD	98242
13	1	FLANGE	33532
12	1	BEARING 6004 2RSC3GJN	91119
11	1	FAN	33816
10	1	BEARING 6201 2RSC3GJN	91120
9	1	ARMATURE	31224
8	9	SCREW TCEI M6x34	93676
7	1	WHEEL \varnothing 245x76	132106
6	1	SEALING	14310
5	1	BEARING 16024	91111
4	1	OR 3775	91536
3	1	SEALING RING	90115
2	2	BEARING 6206 2Z	91133
1	1	IRON CASTING	13042

C	FERODO	12913
B	GEARS	12903
A	GEARS	12944

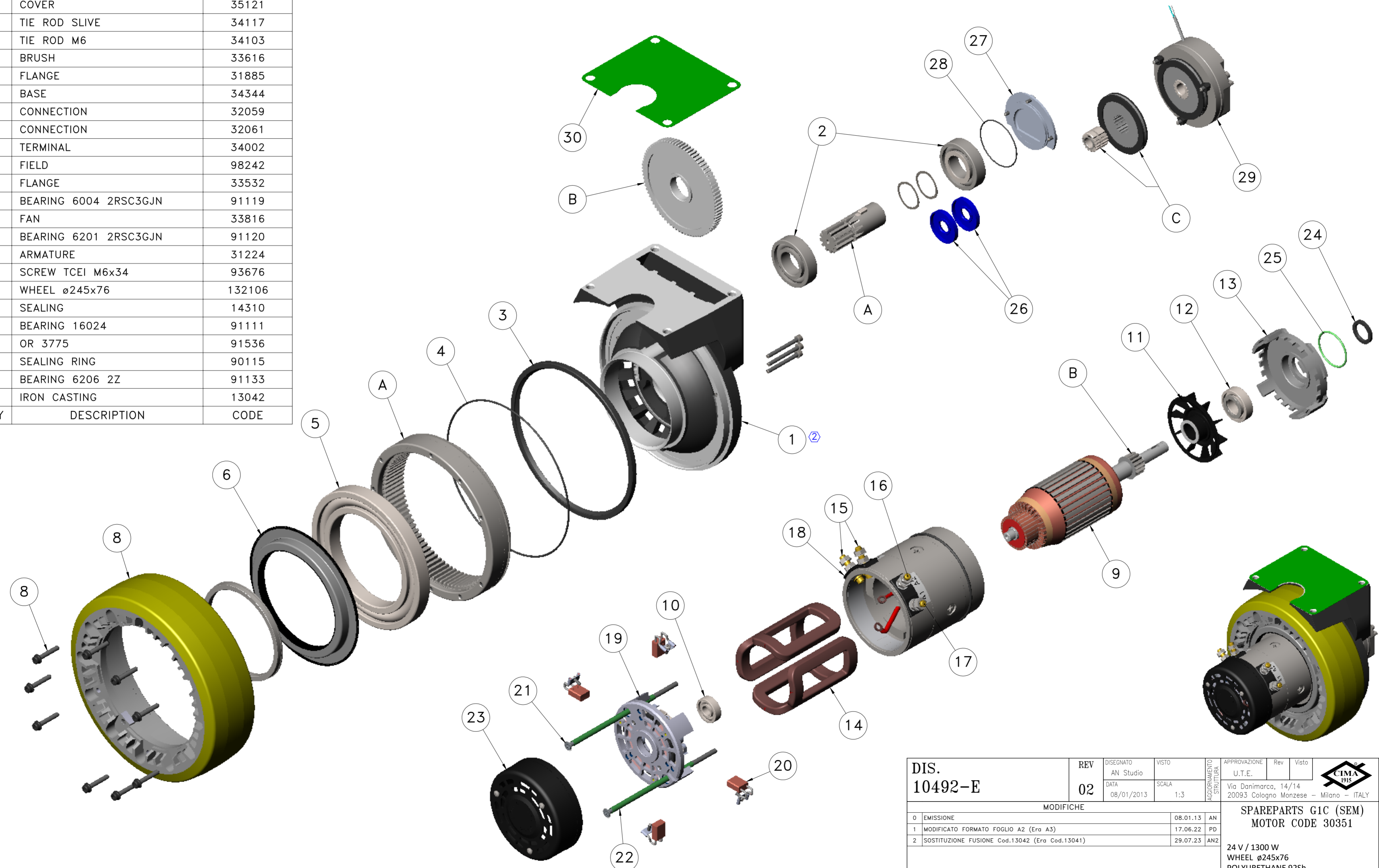

DIS. 10492-E	REV	02	DISegnATO	AN Studio	VISTO	U.T.E.	APPROVAZIONE	Rev	Visto		
	DATA	08/01/2013	SCALA	1:3	AGGIORNAMENTO STRUTTURA	Via Danimarca, 14/14 20093 Cologno Monzese - Milano - ITALY					
MODIFICHE											
0	EMISSIONE						08.01.13	AN	SPAREPARTS G1C (SEM) MOTOR CODE 30351		
1	MODIFICATO FORMATO FOGLIO A2 (Era A3)						17.06.22	PD	24 V / 1300 W WHEEL \varnothing 245x76 POLYURETHANE 92Sh		
2	SOSTITUZIONE FUSIONE Cod.13042 (Era Cod.13041)						29.07.23	AN2	Project Nr. -		

CODICE 10492-E

Disegno eseguito con SW non sono ammesse variazioni o modifiche manuali