

POS.	Q.TY	DESCRIPTION	CODE
26	1	GASKET	13902
25	1	COVER	14101
24	1	GASKET	13901
23	1	SEALING	90123
22	1	O-RING OR 3168	91528
21	1	BRAKE ϕ 84CR	11114
20	1	END COVER	33701
19	1	TIE ROD M6	34123
18	1	TIE ROD M6	34111
17	1	BRAKE PLATE	13703
16	4	BRUSH	33623
15	1	FLANGE	31881
14	1	BEARING 6201 2RSC3GJN	91120
13	1	BASE	34344
12	1	CONNECTION	32059
11	1	CONNECTION	32061
10	1	FLANGE	33461
9	1	BEARING 6004 2RSC3GJN	91119
8	1	ARMATURE	31290
7	8	SCREW TCEI M5x34	93642
6	1	WHEEL ϕ 250x76	13265
5	1	SEALING	14310
4	1	BEARING 16024	91111
3	1	SEALING RING	13806
2	2	BEARING 6006 2Z	91110
1	1	AL CASTING	13051

C	FERODO	12914
B	GEARS	12903
A	GEARS	12938

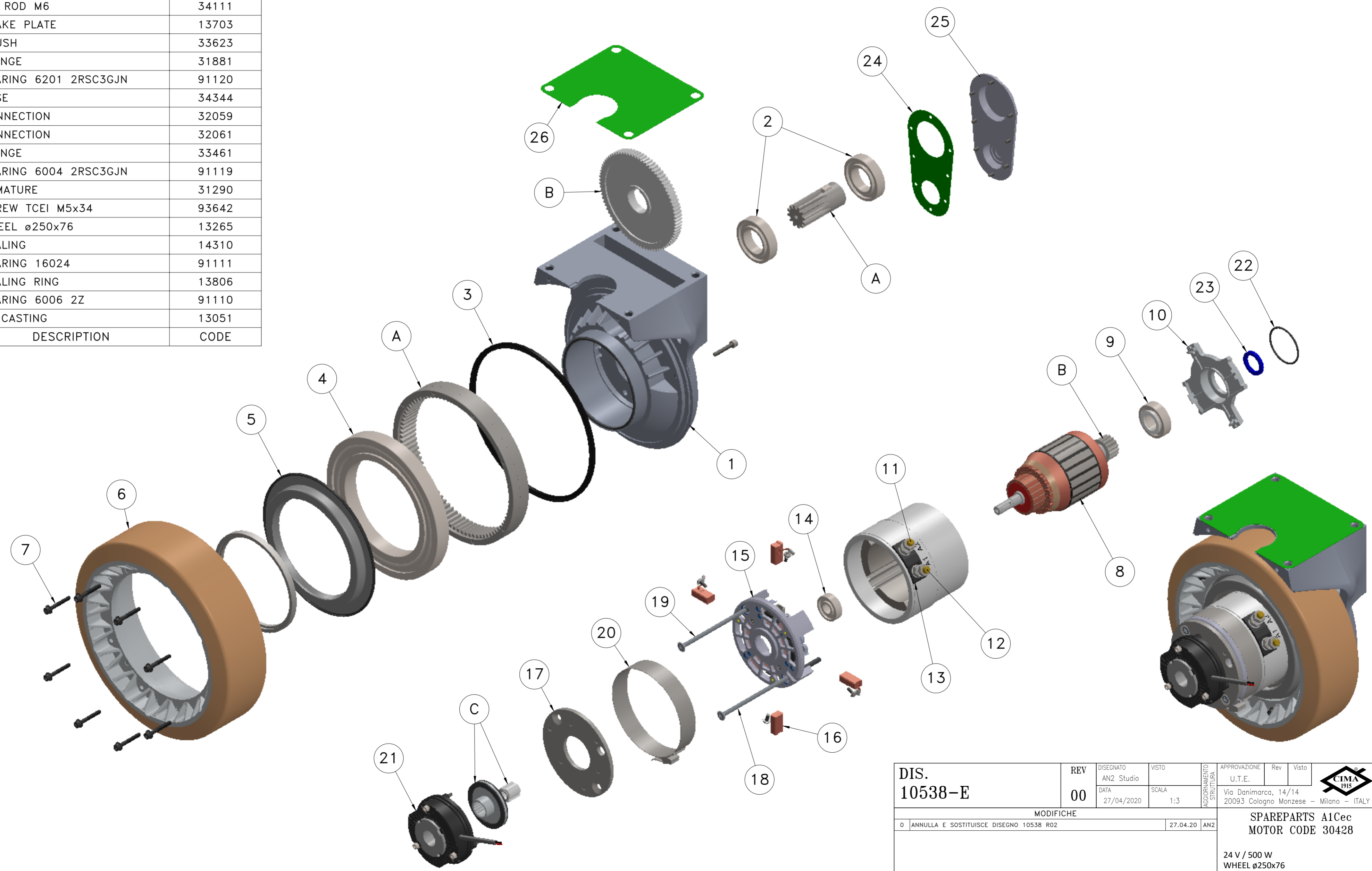

DIS. 10538-E	REV	00	DISEGNATO	AN2 Studio	VISTO		APPROVAZIONE	U.T.E.	
	DATA	27/04/2020	SCALA	1:3	AGGIORNAMENTO STRUTTURA		Via Danimarca, 14/14 20093 Cologno Monzese - Milano - ITALY		
MODIFICHE							27.04.20	ANZ	SPAREPARTS A1Cec MOTOR CODE 30428 24 V / 500 W WHEEL ϕ 250x76 RUBBER 70+72Sh Project Nr. -
0 ANNULLA E SOSTITUISCE DISEGNO 10538 R02									

CODICE 10538-E