

POS.	Q.TY	DESCRIPTION	CODE
25	1	GASKET	13915
24	1	COVER	14101
23	1	GASKET	13901
22	1	SEALING	90123
21	1	O-RING OR 3168	91528
20	1	COVER	35122
19	1	TIE ROD M6	34124
18	1	TIE ROD M6	34105
17	4	BRUSH	33616
16	1	FLANGE	31885
15	1	BASE	34344
14	1	CONNECTION	32059
13	1	CONNECTION	32061
12	1	FLANGE	33461
11	1	BEARING 6201 2RSC3GJN	91120
10	1	BEARING 6004 2RSC3GJN	91119
9	1	ARMATURE	31415
8	10	SCREW TCEI M5x34	93642
7	1	WHEEL $\varnothing 250 \times 76$	13290
6	1	SEALING	14310
5	1	BEARING 16024	91111
4	1	O-RING OR3725	91534
3	1	SEALING RING	90115
2	2	BEARING 6006 2Z	91110
1	1	AL CASTING	13054

C		
B	GEARS	12903
A	GEARS	12946

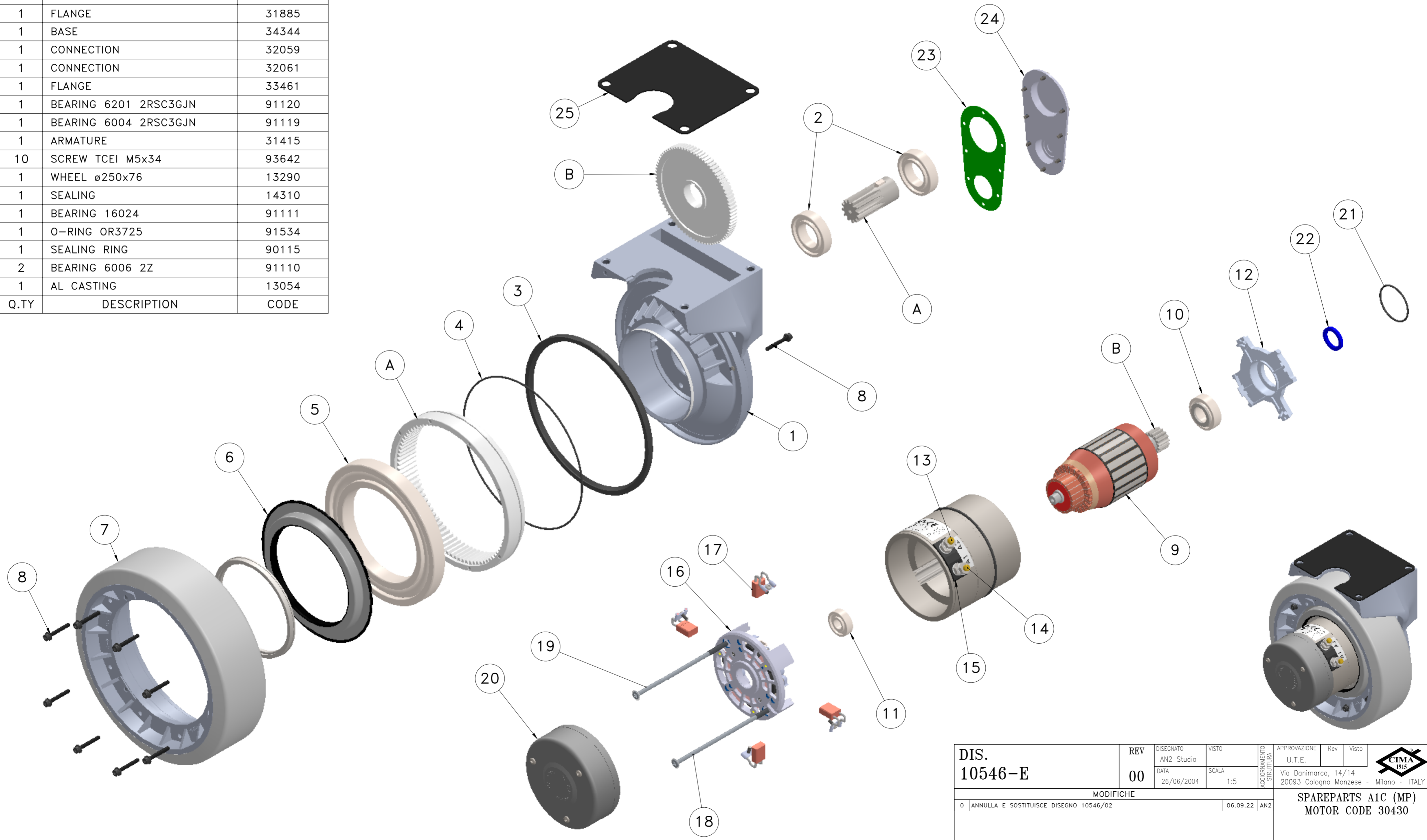

DIS. 10546-E	REV	00	DISegnATO	AN2 Studio	VISTO		APPROVAZIONE	U.T.E.	Rev	Visto			
	DATA	26/06/2004	SCALA	1:5	AGGIORNAMENTO STRUTTURA		Via Danimarca, 14/14 20093 Cologno Monzese - Milano - ITALY						
MODIFICHE												<b>SPAREPARTS A1C (MP)</b> <b>MOTOR CODE 30430</b>  $\varnothing 250 \times 76$ NON MARKING RUBBEN GREY 70÷72Sh	CODICE 10546-E
0 ANNULLA E SOSTITUISCE DISEGNO 10546/02						06.09.22 ANZ		Project Nr.		-			