

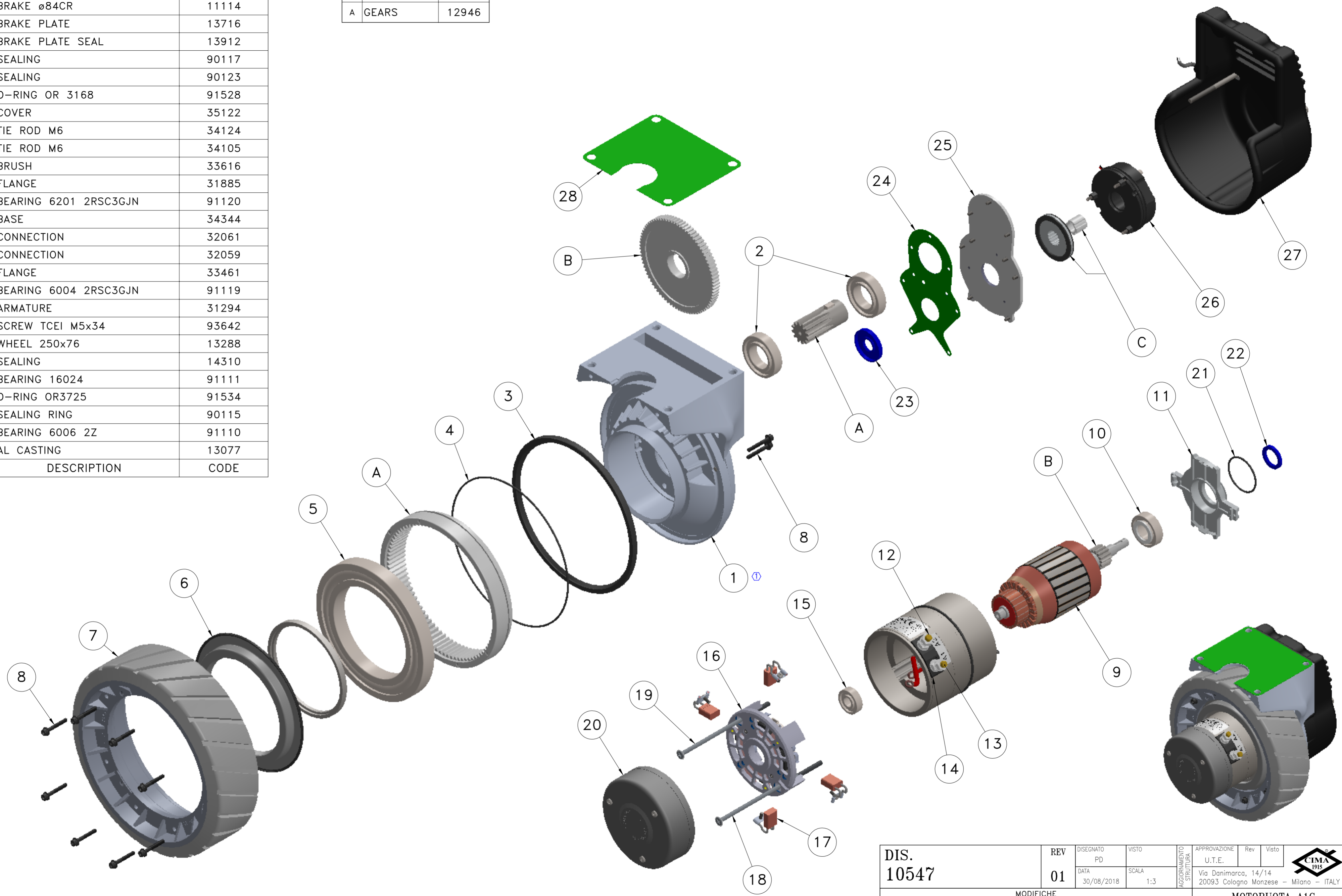

POS.	Q.TY	DESCRIPTION	CODE
28	1	GASKET	13902
27	1	PROTECTION	14422
26	1	BRAKE $\varnothing$ 84CR	11114
25	1	BRAKE PLATE	13716
24	1	BRAKE PLATE SEAL	13912
23	1	SEALING	90117
22	1	SEALING	90123
21	1	O-RING OR 3168	91528
20	1	COVER	35122
19	1	TIE ROD M6	34124
18	1	TIE ROD M6	34105
17	1	BRUSH	33616
16	1	FLANGE	31885
15	1	BEARING 6201 2RSC3GJN	91120
14	1	BASE	34344
13	1	CONNECTION	32061
12	1	CONNECTION	32059
11	1	FLANGE	33461
10	1	BEARING 6004 2RSC3GJN	91119
9	1	ARMATURE	31294
8	12	SCREW TCEI M5x34	93642
7	1	WHEEL 250x76	13288
6	1	SEALING	14310
5	1	BEARING 16024	91111
4	1	O-RING OR3725	91534
3	1	SEALING RING	90115
2	2	BEARING 6006 2Z	91110
1	1	AL CASTING	13077

C	FERODO	12914
B	GEARS	12903
A	GEARS	12946



DIS. 10547	REV	01	DISegnato	PD	VISTO	SCALA	1:3	APPROVAZIONE	U.T.E.	Rev	Visto	 Via Danimarca, 14/14 20093 Cologno Monzese - Milano - ITALY
	DATA	30/08/2018	AGGIORNAMENTO	STRUTTURA	APPROVAZIONE	Rev	Visto	30.08.18	PD			
MODIFICHE										MOTORUOTA A1C MOTORE $\varnothing$ 114 (MP)		
0 ANNULLA E SOSTITUISCE DIS. 10547/03 Rub.I										24 V / 700 W		
1 CRM 2000102-SOSTITUITO FUSIONE Cod.13077 (Era Cod.13058)										$\varnothing$ 250x76 GOMMA ECO GRIGIA SCOLP		
										FRENO $\varnothing$ 84CR		
										Project Nr.		

CODICE 10547