

POS.	Q.TY	DESCRIPTION	CODE
31	1	GASKET	13902
30	1	PROTECTION	14415
29	1	OR 2225	91556
28	1	COVER	14104
27	2	SEALING	90117
26	1	OR 3168	91554
25	1	SEALING	90118
24	1	COVER	35121
23	2	TIE ROD SLIVE	34117
22	2	TIE ROD M6	34103
21	4	BRUSH	33616
20	1	FLANGE	31885
19	2	BASE	34344
18	1	CONNECTION	32059
17	1	CONNECTION	32061
16	2	TERMINAL	34002
15	1	FIELD	31690
14	1	FLANGE	33532
13	1	BEARING 6004 2RSC3GJN	91119
12	1	FAN	33816
11	1	BEARING 6201 2RSC3GJN	91120
10	1	ARMATURE	31224
9	9	SCREW TCEI M6x34	93676
8	1	WHEEL ø260x101	132132
7	1	SEALING	14310
6	1	BEARING 16024	91111
5	1	OR 3775	91536
4	1	SEALING RING	90115
3	2	COMPENSATION RING	92702
2	2	BEARING 6206 2Z	91133
1	1	IRON CASTING	13042

C		
B	GEARS	12903
A	GEARS	12944

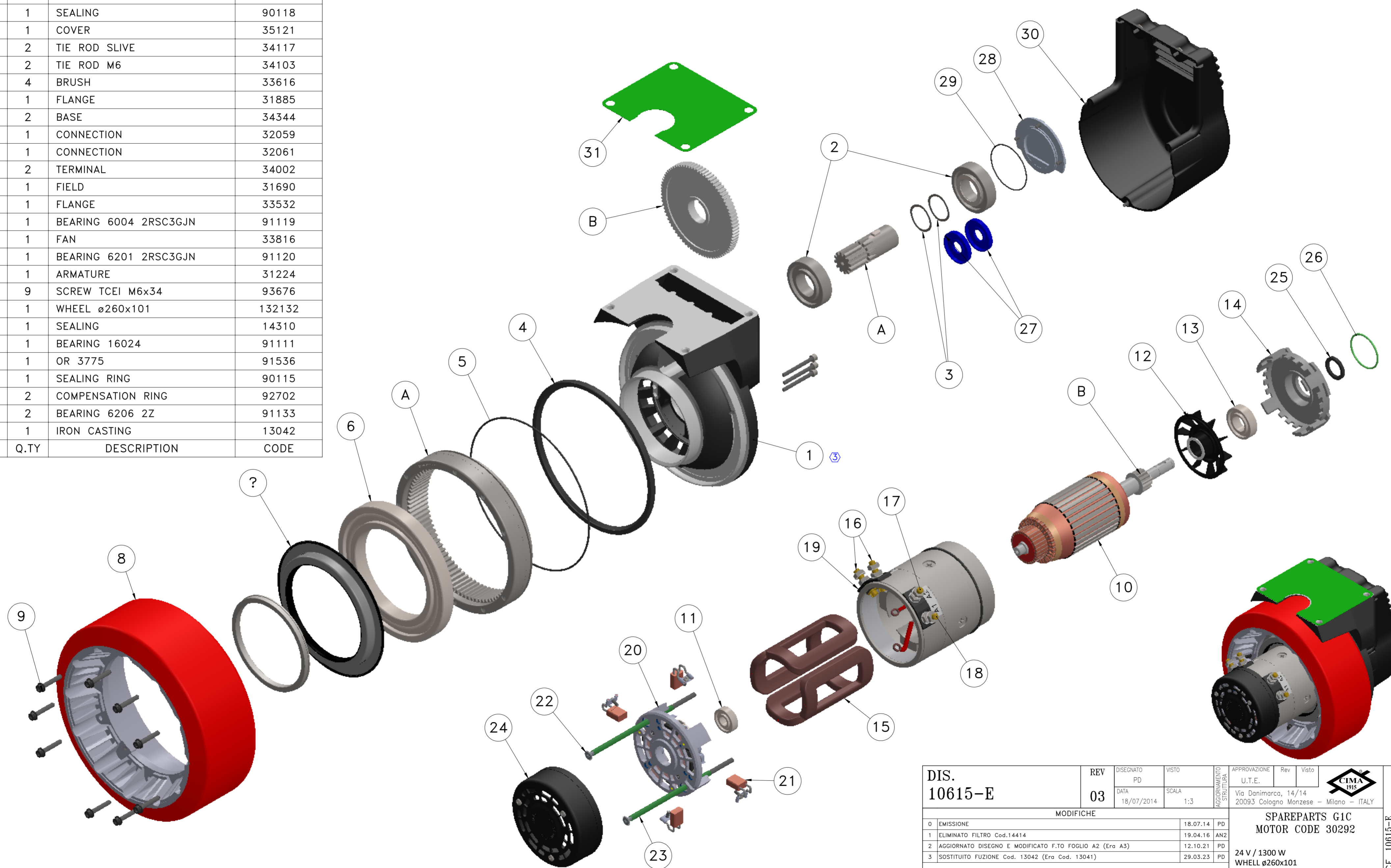

DIS. 10615-E	REV	03	DISEGNATO	PD	VISTO		APPROVAZIONE	U.T.E.	Rev	Visto			
	DATA	18/07/2014	SCALA	1:3	AGGIORNAMENTO STRUTTURA		Via Danimarca, 14/14 20093 Cologno Monzese - Milano - ITALY						
MODIFICHE												SPAREPARTS G1C MOTOR CODE 30292 24 V / 1300 W WHELL ø260x101 ELAST. ANTISKID RED Project Nr. -	
0	EMISSIONE										18.07.14		PD
1	ELIMINATO FILTRO Cod.14414										19.04.16		AN2
2	AGGIORNATO DISEGNO E MODIFICATO F.TO FOGLIO A2 (Era A3)										12.10.21		PD
3	SOSTITUITO FUZIONE Cod. 13042 (Era Cod. 13041)										29.03.23	PD	

Formato: A2 - Disegno eseguito con SW non sono ammesse variazioni o modifiche manuali
 CODICE 10615-E