

30	1	SEALING	90118
29	1	OR 3168	91554
28	1	FLANGE	33460
27	1	BEARING	91119
26	2	SEEGER AS14	93209
25	1	ARMATURE	31245
24	1	CONNECTION	32060
23	1	CONNECTION	32059
22	2	TERMINAL	34002
21	2	BASE	34345
20	1	FIELD	31645
19	1	BEARING	91121
18	1	FLANGE	31856
17	8	BRUSH	33620
16	1	KIT VENTILATION	12813
15	1	PROTECTION	14415
13	1	PLATE	13724
12	1	SEAL PLATE	13920
11	1	SEALING	90117
10	2	BEARING	91133
9	1	GASKET	13911
8	1	IRON CASTING	13044
7	1	SEALING RING	13806
6	1	SEALING RING	90111
5	1	OR 3775	91536
4	2	BEARING	91111
3	1	SEALING	14310
2	1	WHEEL	13228
1	9	SCREW	93624
POS.	Q.TY	DESCRIPTION	CODE

*ASSEMBLY OLD TYPE			
32*	1	FILTER	14414
25*	1	ARMATURE WITH NUT	31245
13*	1	COVER	14101
12*	1	SEAL COVER	13901
11*	1	PLUG	14016
10*	3	BEARING	91109
POS.	Q.TY	DESCRIPTION	CODE

B	GEARS	12941
A	GEARS	12988
A*	GEARS	12942

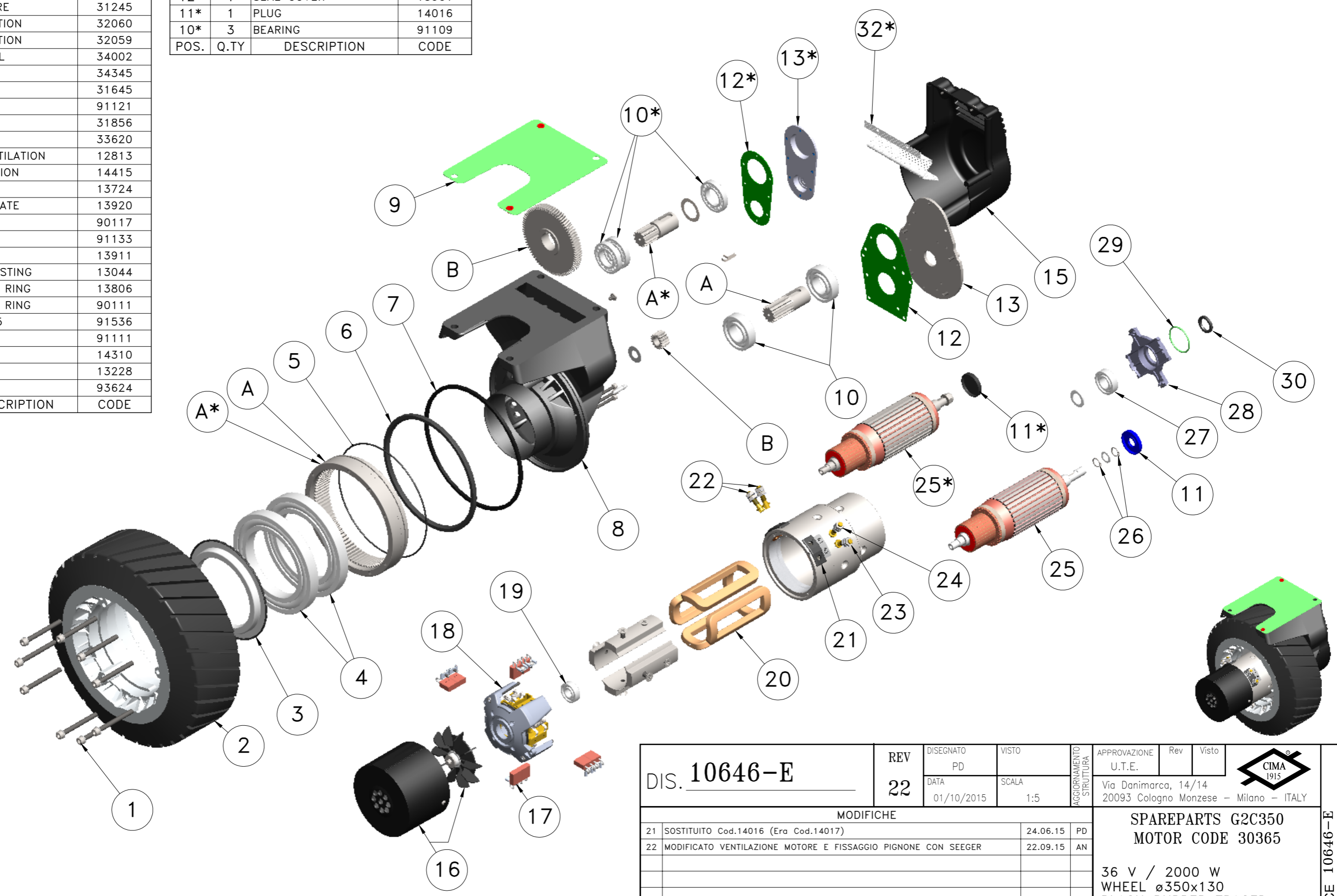

DIS. 10646-E	REV	DISEGNATO	VISTO	AGGIORNAMENTO STRUTTURA	APPROVAZIONE	Rev	Visto	
	22	PD			U.T.E.			
		DATA	SCALA		Via Danimarca, 14/14 20093 Cologno Monzese - Milano - ITALY			
		01/10/2015	1:5		SPAREPARTS G2C350 MOTOR CODE 30365			
		MODIFICHE			36 V / 2000 W WHEEL ø350x130 BLACK RUBBER TRACED			
		21	SOSTITUITO Cod.14016 (Era Cod.14017)		24.06.15	PD		
		22	MODIFICATO VENTILAZIONE MOTORE E FISSAGGIO PIGNONE CON SEEGER		22.09.15	AN		
								CODICE 10646-E
						Project Nr.		

Formato: A3 Disegno eseguito con SW non sono ammesse variazioni o modifiche manuali