

1	2	3	4	5	6	7	8	9	10
30	1	GASKET	13911						
29	1	PROTECTION	14415						
28	1	BRAKE ø124CR	11127						
27	1	PLATE	13724						
26	1	SEAL PLATE	13920						
25	2	SEALING	90117						
24	4	SEEGER AS14 DIN 471	93209						
23	1	FLANGE	31856						
22	1	SEALING	90123						
21	1	OR 3168	91554						
20	1	KIT VENTILATION	12813						
19	8	BRUSH	33620						
18	1	BEARING 6202 2RSC3GJN	91121						
17	1	CONNECTION	32059						
16	1	CONNECTION	32060						
15	2	BASE	34345						
14	2	TERMINAL	34002						
13	1	FIELD	31685						
12	1	FLANGE	33460						
11	1	BEARING 6004 2RSC3GJN	91119						
10	1	ARMATURE	31286						
9	9	SCREW M8 ISO4762	93624						
8	1	WHEEL ø350x130	13228						
7	1	OR 3775	91536						
6	2	BEARING 6206 2Z	91133						
5	1	SEALING	14310						
4	2	BEARING 16024	91111						
3	1	SEALING RING	90111						
2	1	SEALING RING	13806						
1	1	IRON CASTING	13044						
POS.	Q.TY	DESCRIPTION	CODE						

*ASSEMBLY OLD TYPE			
33*	1	FILTER	14414
32*	1	SPACER	91308
31*	1	OR 2018	91508
27*	1	PLATE	13712
26*	1	SEAL PLATE	13909
25*	1	SEALING	90116
10*	1	ARMATURE WITH NUT	31286
6*	3	BEARING 16006	91109
POS.	Q.TY	DESCRIPTION	CODE

C	FERODO	12916
B	GEARS	12941
A	GEARS	12988
A*	GEARS	12942

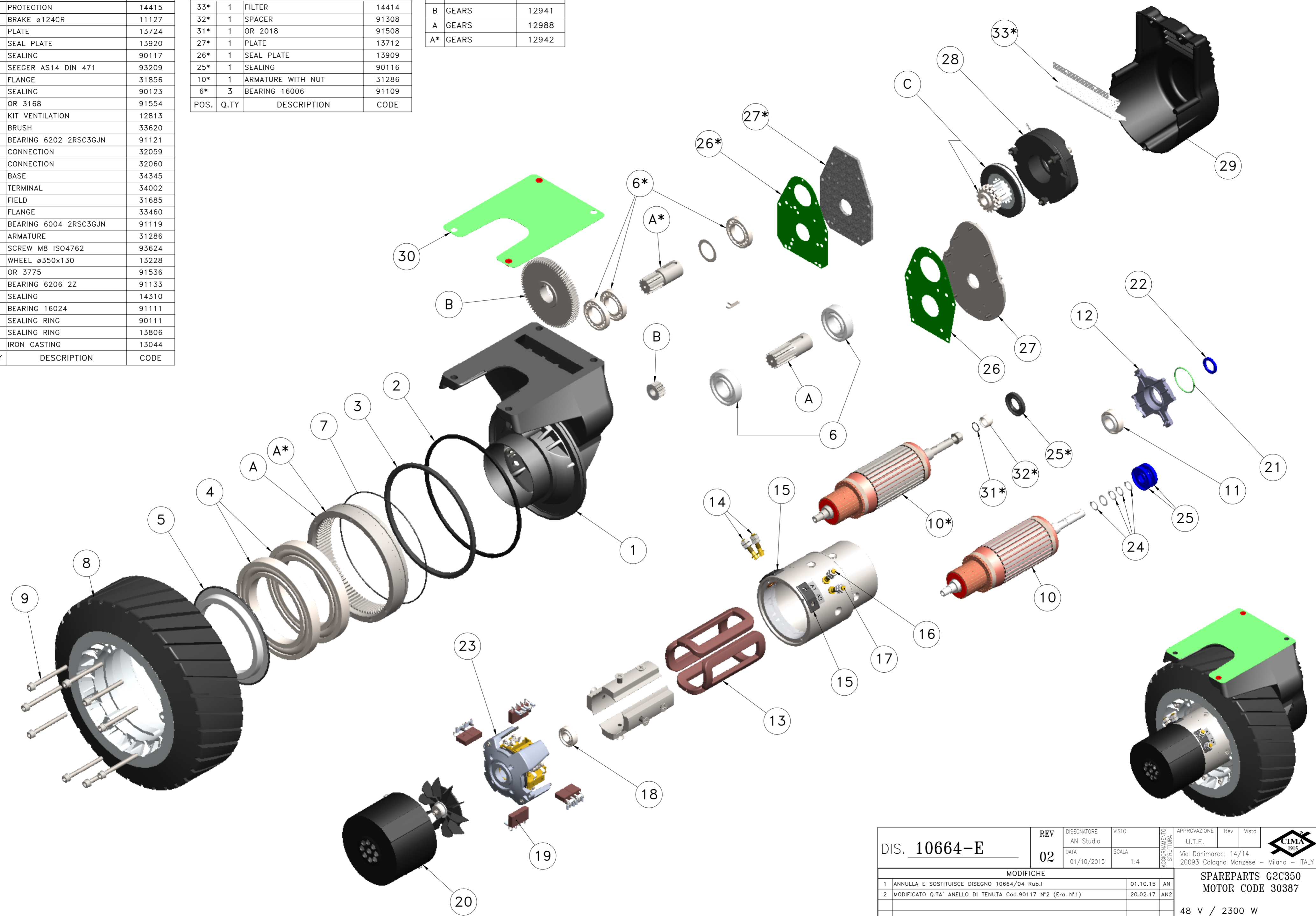

DIS. 10664-E	REV	02	DISEGNATORE	AN Studio	VISTO		APPROVAZIONE	U.T.E.	Rev	Visto												
	DATA	01/10/2015	SCALA	1:4	AGGIORNAMENTO STRUTTURA		Via Danimarca, 14/14 20093 Cologno Monzese - Milano - ITALY															
<table border="1"> <thead> <tr> <th colspan="3">MODIFICHE</th> </tr> </thead> <tbody> <tr> <td>1</td> <td>ANNULLA E SOSTITUISCE DISEGNO 10664/04 Rub.1</td> <td>01.10.15 AN</td> </tr> <tr> <td>2</td> <td>MODIFICATO Q.TA' ANELLO DI TENUTA Cod.90117 N°2 (Era N°1)</td> <td>20.02.17 AN2</td> </tr> </tbody> </table>												MODIFICHE			1	ANNULLA E SOSTITUISCE DISEGNO 10664/04 Rub.1	01.10.15 AN	2	MODIFICATO Q.TA' ANELLO DI TENUTA Cod.90117 N°2 (Era N°1)	20.02.17 AN2	SPAREPARTS G2C350 MOTOR CODE 30387 48 V / 2300 W WHEEL ø350x130 BLACK RUBBER TRACED	Project Nr.
MODIFICHE																						
1	ANNULLA E SOSTITUISCE DISEGNO 10664/04 Rub.1	01.10.15 AN																				
2	MODIFICATO Q.TA' ANELLO DI TENUTA Cod.90117 N°2 (Era N°1)	20.02.17 AN2																				
Project Nr.																						

S:\Archivio\Directorio\Nuove\ArchivioDocumentazione\CLIENTI\ESPLOSI RICAMBI\Motoriute Ghiso\

Formato: A2 - Disegno eseguito con SW non sono ammesse variazioni o modifiche manuali

CODICE 10664-E