

POS.	Q.TY	DESCRIPTION	CODE
31	1	BRAKE ø124CR	11125
30	1	GASKET	13902
29	1	OR 2225	91556
28	1	COVER	14104
27	2	SEALING	90117
26	1	OR 3168	91554
25	1	SEALING	90118
24	1	COVER	35121
23	2	TIE ROD SLIVE	34117
22	2	TIE ROD M6	34103
21	4	BRUSH	33616
20	1	FLANGE	31885
19	2	BASE	34344
18	1	CONNECTION	32059
17	1	CONNECTION	32061
16	2	TERMINAL	34002
15	1	FIELD	98242
14	1	FLANGE	33532
13	1	BEARING 6004 2RSC3GJN	91119
12	1	FAN	33816
11	1	BEARING 6201 2RSC3GJN	91120
10	1	ARMATURE	31224
9	9	SCREW TCEI M6x34	93676
8	1	WHEEL ø250x101	13278
7	1	SEALING	14310
6	1	BEARING 16024	91111
5	1	OR 3775	91536
4	1	SEALING RING	90115
3	2	COMPENSATION RING	92702
2	2	BEARING 6206 2Z	91133
1	1	IRON CASTING	13042

C		
B	GEARS	12903
A	GEARS	12944

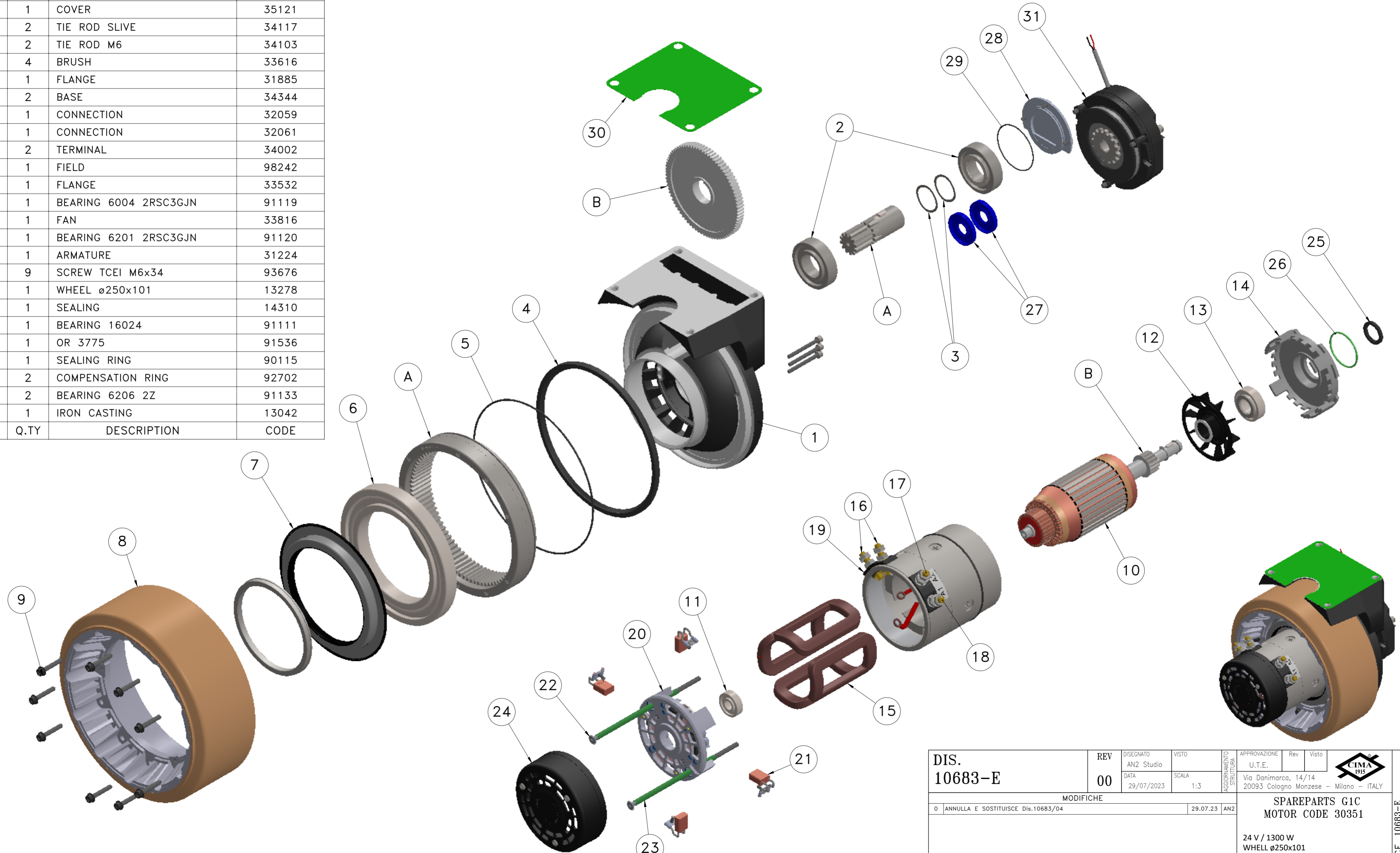

DIS. 10683-E	REV	00	DISEGNATO	AN2 Studio	VISTO		APPROVAZIONE	U.T.E.	
	DATA	29/07/2023	SCALA	1:3	AGGIORNAMENTO STRUTTURA		Via Danimarca, 14/14 20093 Cologno Monzese - Milano - ITALY		
MODIFICHE							29.07.23	AN2	SPAREPARTS G1C MOTOR CODE 30351 24 V / 1300 W WHELL ø250x101 RUBBER 70+72Sh Project Nr. -
0 ANNULLA E SOSTITUISCE Dis.10683/04									

Formato: A2 - Disegno eseguito con SW non sono ammesse variazioni o modifiche manuali
 CODICE 10683-E