

POS.	Q.TY	DESCRIPTION	CODE
16	1	GASKET	13902
15	1	BRAKE ø84SR	11104
14	1	OR 2225	91556
13	1	COVER	14104
12	2	SEALING	90117
11	6	SCREW TCEI M5x34	93642
10	1	MOTOR	30820
9	9	SCREW TCEI M6x34	93676
8	1	WHEEL ø250x101	13278
7	1	SEALING	14310
6	1	BEARING 16024	91111
5	1	OR 3775	91536
4	1	SEALING RING	90115
3	2	COMPENSATION RING	92702
2	2	BEARING 6206 2Z	91133
1	1	IRON CASTING	13041

C	FERODO	12914
B	GEARS	12903
A	GEARS	12944

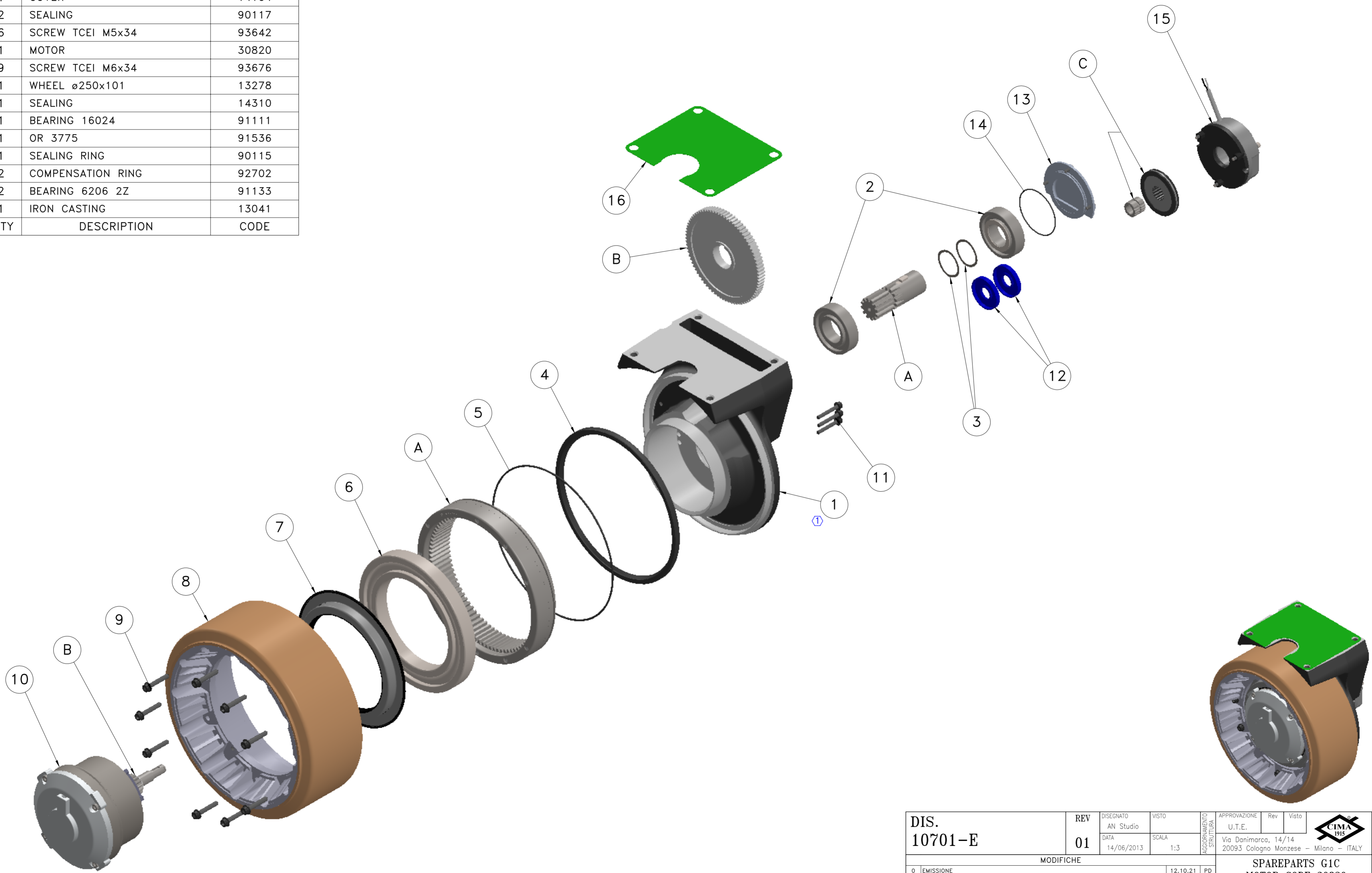

DIS. 10701-E	REV	01	DISEGNATO	AN Studio	VISTO	U.T.E.	APPROVAZIONE	Rev	Visto	
	DATA	14/06/2013	SCALA	1:3	AGGIORNAMENTO STRUTTURA	Via Danimarca, 14/14 20093 Cologno Monzese - Milano - ITALY				
MODIFICHE										
0	EMISSIONE				12.10.21	PD	<b>SPAREPARTS G1C</b> <b>MOTOR CODE 30820</b>  WHEEL ø250x101 RUBBER 70+72Sh Project Nr. -			
1	SOSTITUITO FUSIONE Cod.13041 (Era Cod.13042)				29.07.23	AN2				

CODICE 10701-E