

POS.	Q.TY	DESCRIPTION	CODE
29	1	CLAMP	33745
28	1	GASKET	13918
27	1	CAP	14018
26	1	CLOSING PLATE	13730
25	1	SEALING	90123
24	2	CUP	14015
23	1	PROTECTION CAP BRAKE	14013
22	1	BRAKE $\phi$ 104CR	11117
21	1	BRAKE PLATE	13703
20	1	SPEED SENSOR	70022
19	1	BASE	34341
18	4	TIE ROD	34110
17	1	FLANGE	33554
16	1	BEARING 6202 2RSC3GJN	91121
15	1	STATOR FIELD	31036T
14	1	FLANGE	33584
13	1	BEARING 6204 2Z	91108
12	1	FONIC WHEEL	13347
11	1	ROTOR	31196
10	1	OR 3225	91563
9	1	SEALING	14310
8	1	OR 110-3	91557
7	1	COVER	14105
6	1	GASKET	13917
5	2	BEARING 6006 2Z	91110
4	1	BEARING 16024	91111
3	1	OR 3775	91536
2	1	SEALING RING	90115
1	1	AL CASTING	13072

C	FERODO	12913
B	GEARS	12903
A	GEARS	12803

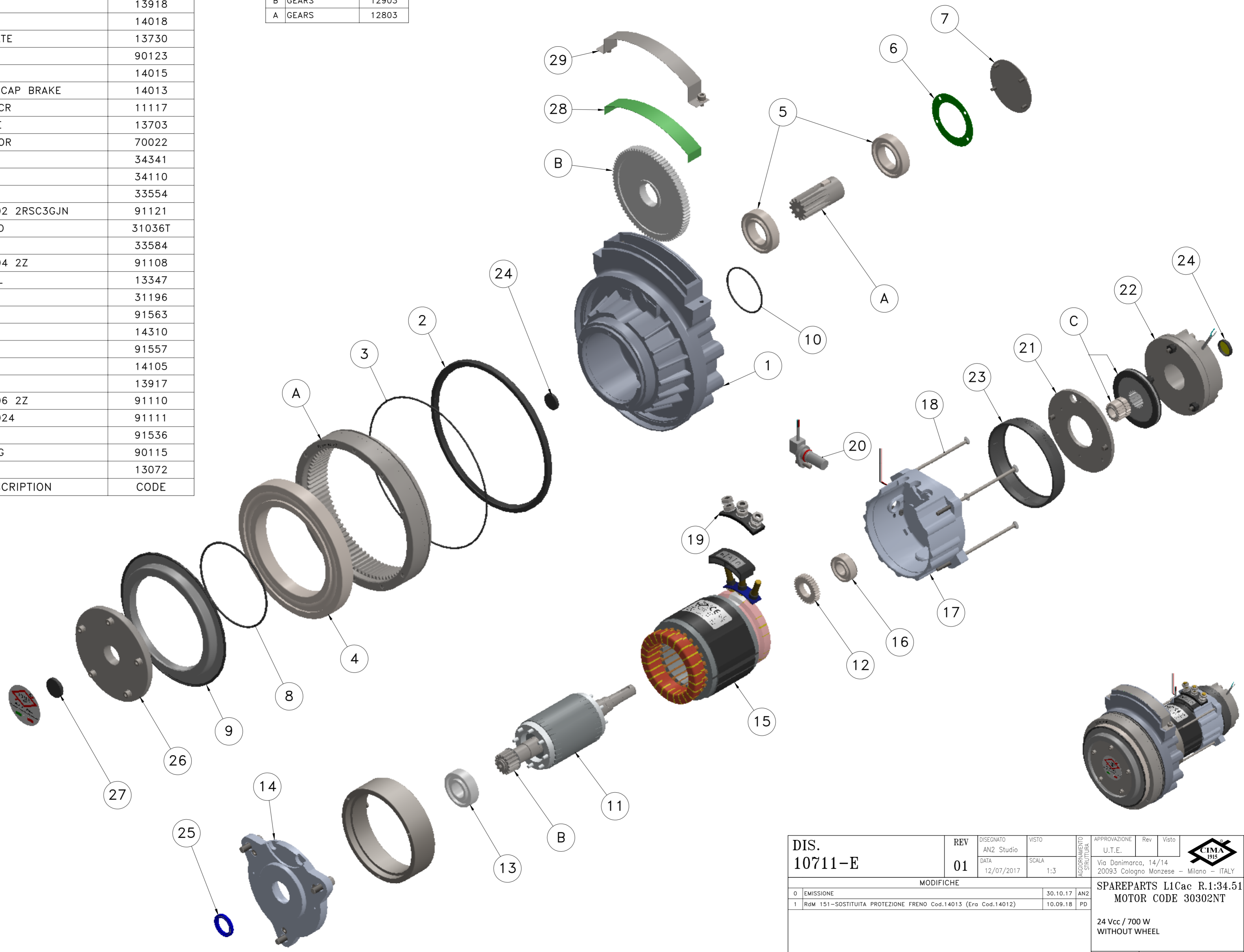

DIS. 10711-E	REV 01	DESIGNATO AN2 Studio	VISTO	APPROVAZIONE U.T.E.	
		DATA 12/07/2017	SCALA 1:3	Via Danimarca, 14/14 20093 Cologno Monzese - Milano - ITALY	
MODIFICHE					
0	EMMISSIONE		30.10.17	ANZ	SPAREPARTS L1Cac R.1:34.51 MOTOR CODE 30302NT  24 Vcc / 700 W WITHOUT WHEEL
1	RdM 151-SOSTITUITA PROTEZIONE FRENO Cod.14013 (Era Cod.14012)		10.09.18	PD	
				Project Nr.	00123