

POS.	Q.TY	DESCRIPTION	CODE
28	1	CLAMP	33745
27	1	GASKET	13918
26	1	BRAKE F84SR 10Nm	11133
25	1	BRAKE PLATE	13722
24	2	SEALING	90129
23	1	SEALING	90123
22	1	COVER	35122
21	2	TIE ROD M6	34104
20	4	BRUSH	33616
19	1	FLANGE	31885
18	1	BEARING 6201 2RSC3GJN	91120
17	1	BASE	34344
16	1	CONNECTION	32059
15	1	CONNECTION	32061
14	1	FLANGE	33573
13	1	BEARING 6204 2Z	91108
12	1	ARMATURE	313116
11	1	OR 3225	91563
10	1	WHEEL RIM ø215x76	132180
9	1	SEALING	14310
8	1	OR 110-3	91557
7	1	COVER	14105
6	1	GASKET	13917
5	2	BEARING 6006 2Z	91110
4	1	BEARING 16024	91111
3	1	OR 3775	91536
2	1	SEALING RING	90115
1	1	AL CASTING	13072

C	FERODO	12914
B	GEARS	12970
A	GEARS	12921

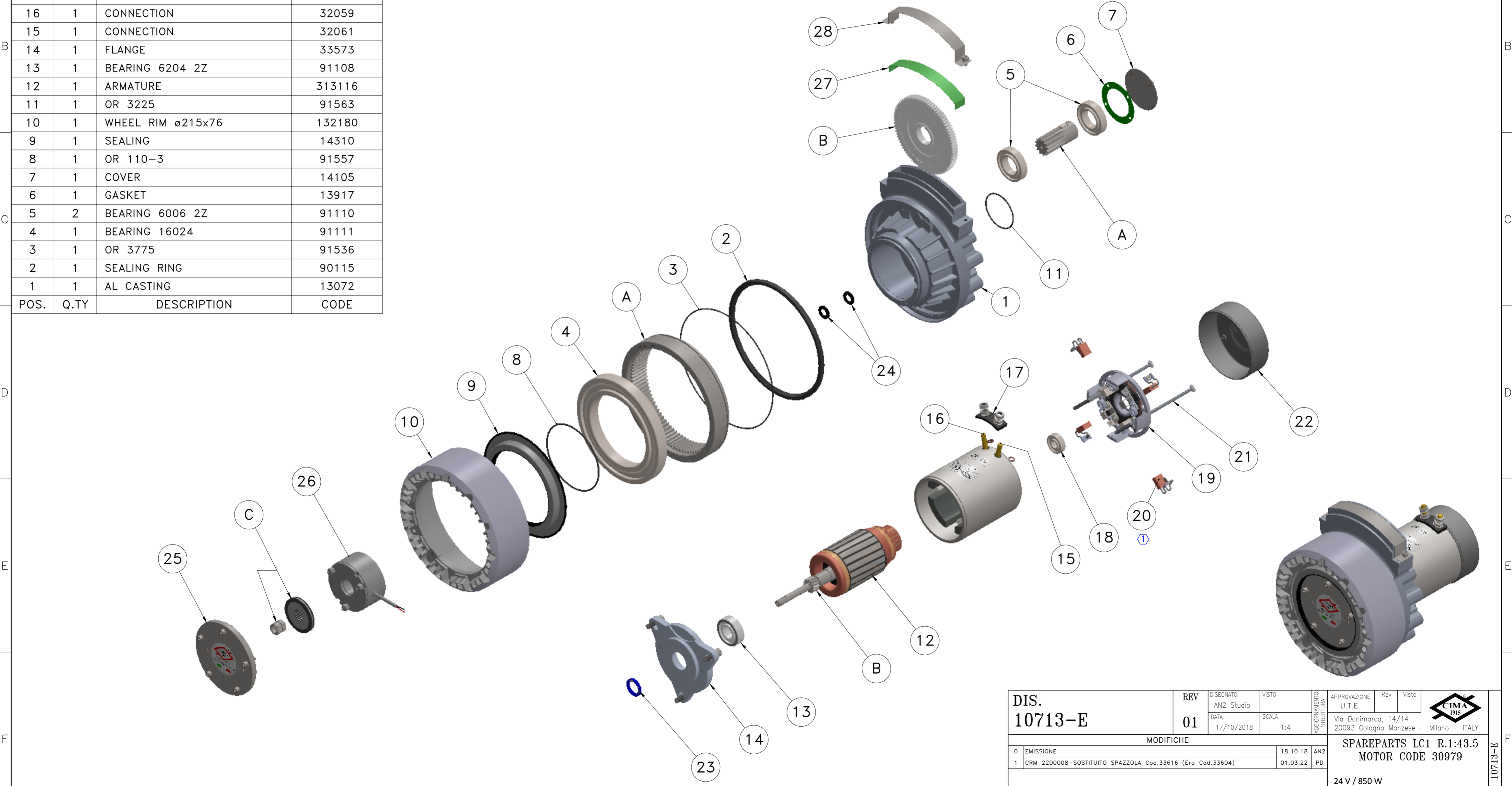

DIS. 10713-E	REV	01	DISEGNATO	AN2 Studio	VISTO		APPROVAZIONE	U.T.E.	Rev	Visto	
	DATA	17/10/2018	SCALA	1:4	AGGIORNAMENTO STRUTTURA		Via Danimarca, 14/14 20093 Cologno Monzese - Milano - ITALY				
MODIFICHE											
0	EMISSIONE					18.10.18	ANZ	SPAREPARTS LC1 R.1:43.5			
1	CRM 2200008-SOSTITUITO SPAZZOLA Cod.33616 (Era Cod.33604)					01.03.22	PD	MOTOR CODE 30979			
24 V / 850 W WHEEL ø215x76 Project Nr. 1800002											

Formato: A2 - Disegno eseguito con SW non sono ammesse variazioni o modifiche manuali
 CODICE 10713-E