

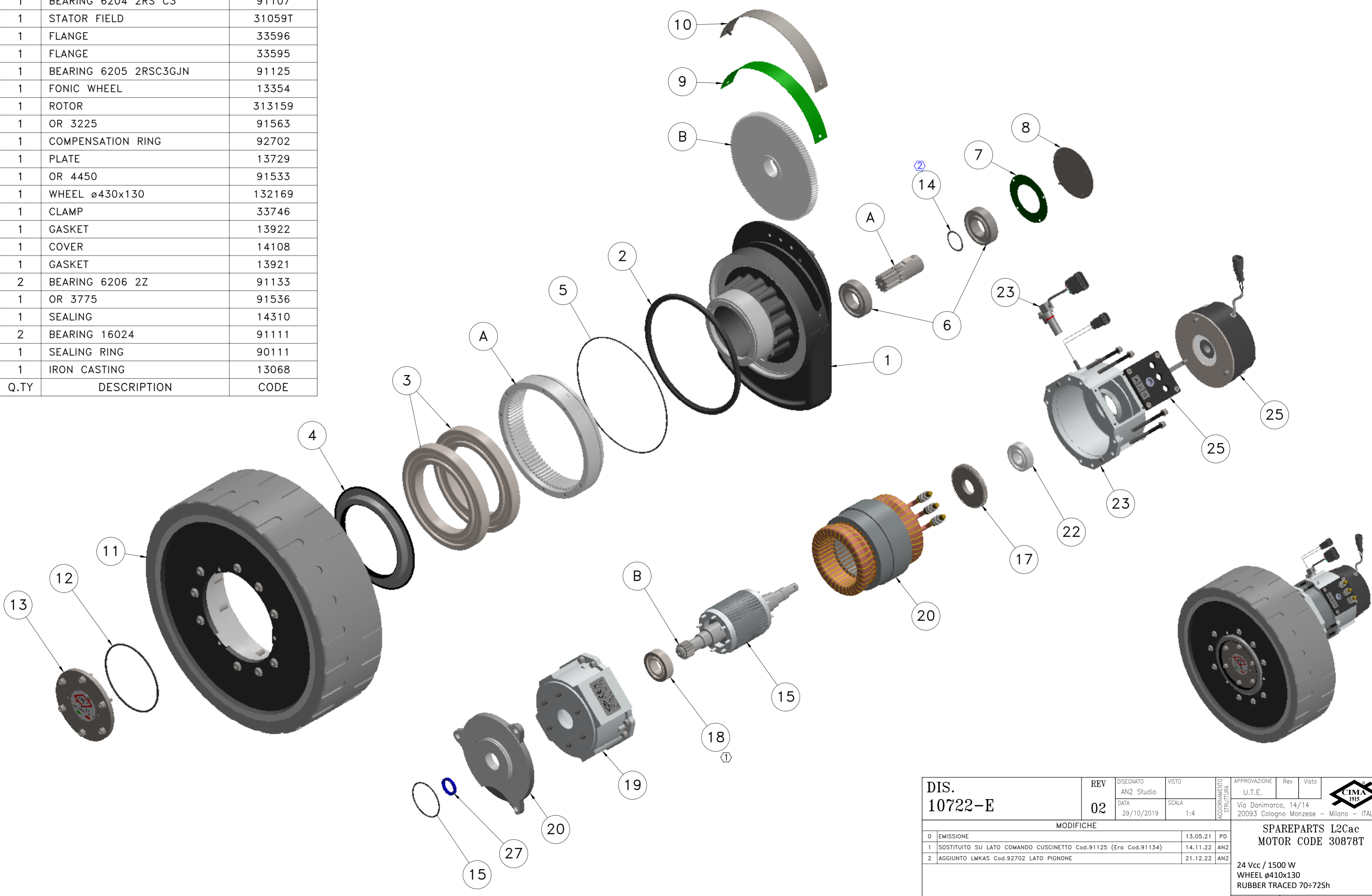

POS.	Q.TY	DESCRIPTION	CODE
27	1	SEALING	90123
26	1	BRAKE ø125 IP 65	11193
25	1	BASE	34347
24	1	SPEED SENSOR 35	70027
23	1	FLANGE	34836
22	1	BEARING 6204 2RS C3	91107
21	1	STATOR FIELD	31059T
20	1	FLANGE	33596
19	1	FLANGE	33595
18	1	BEARING 6205 2RSC3GJN	91125
17	1	FONIC WHEEL	13354
16	1	ROTOR	313159
15	1	OR 3225	91563
14	1	COMPENSATION RING	92702
13	1	PLATE	13729
12	1	OR 4450	91533
11	1	WHEEL ø430x130	132169
10	1	CLAMP	33746
9	1	GASKET	13922
8	1	COVER	14108
7	1	GASKET	13921
6	2	BEARING 6206 2Z	91133
5	1	OR 3775	91536
4	1	SEALING	14310
3	2	BEARING 16024	91111
2	1	SEALING RING	90111
1	1	IRON CASTING	13068

B	GEARS	129101
A	GEARS	12988



DIS. 10722-E	REV	02	DESIGNATO	AN2 Studio	VISTO	U.T.E.	APPROVAZIONE	Rev	Visto	 Via Danimarca, 14/14 20093 Cologno Monzese - Milano - ITALY
	DATA	29/10/2019	SCALA	1:4	AGGIORNAMENTO STRUTTURA					
MODIFICHE										
0	EMISSIONE					13.05.21	PD	SPAREPARTS L2Cac MOTOR CODE 30878T 24 Vcc / 1500 W WHEEL ø410x130 RUBBER TRACED 70+72Sh Project Nr. 1900111/01		
1	SOSTITUITO SU LATO COMANDO CUSCINETTO Cod.91125 (Era Cod.91134)					14.11.22	AN2			
2	AGGIUNTO LMKAS Cod.92702 LATO PIGNONE					21.12.22	AN2			

Formato: A2 - Disegno eseguito con SW non sono ammesse variazioni o modifiche manuali
 CODICE 10722-E