

POS.	Q.TY	DESCRIPTION	CODE
29	1	SPEED SENSOR 2048	70034
28	9	SCREW TCEI M6x34	93676
27	1	WHEEL ø300x101	132214
26	1	BRAKE ø84SR	111104
25	1	BRAKE PLATE	13722
24	1	CLAMP	33745
23	1	GASKET	13918
22	2	SEALING	90129
21	1	SEALING	90123
20	1	SPEED SENSOR	70022
19	4	TIE ROD	34110
18	1	BASE	34341
17	1	FLANGE	33591
16	1	BEARING 6202 2RSC3GJN	91121
15	1	STATOR FIELD	31078T
14	1	FLANGE	33584
13	1	BEARING 6204 2Z	91108
12	1	FONIC WHEEL	13347
11	1	ROTOR	313184
10	1	OR 3225	91563
9	1	COVER	14105
8	1	GASKET	13917
7	1	SEALING	14310
6	1	OR 110-3	91557
5	1	BEARING 16024	91111
4	1	OR 3775	91536
3	1	SEALING RING	90115
2	2	BEARING 6006 2Z	91110
1	1	AL CASTING	13072

C	FERODO	12914
B	GEARS	12931
A	GEARS	12921

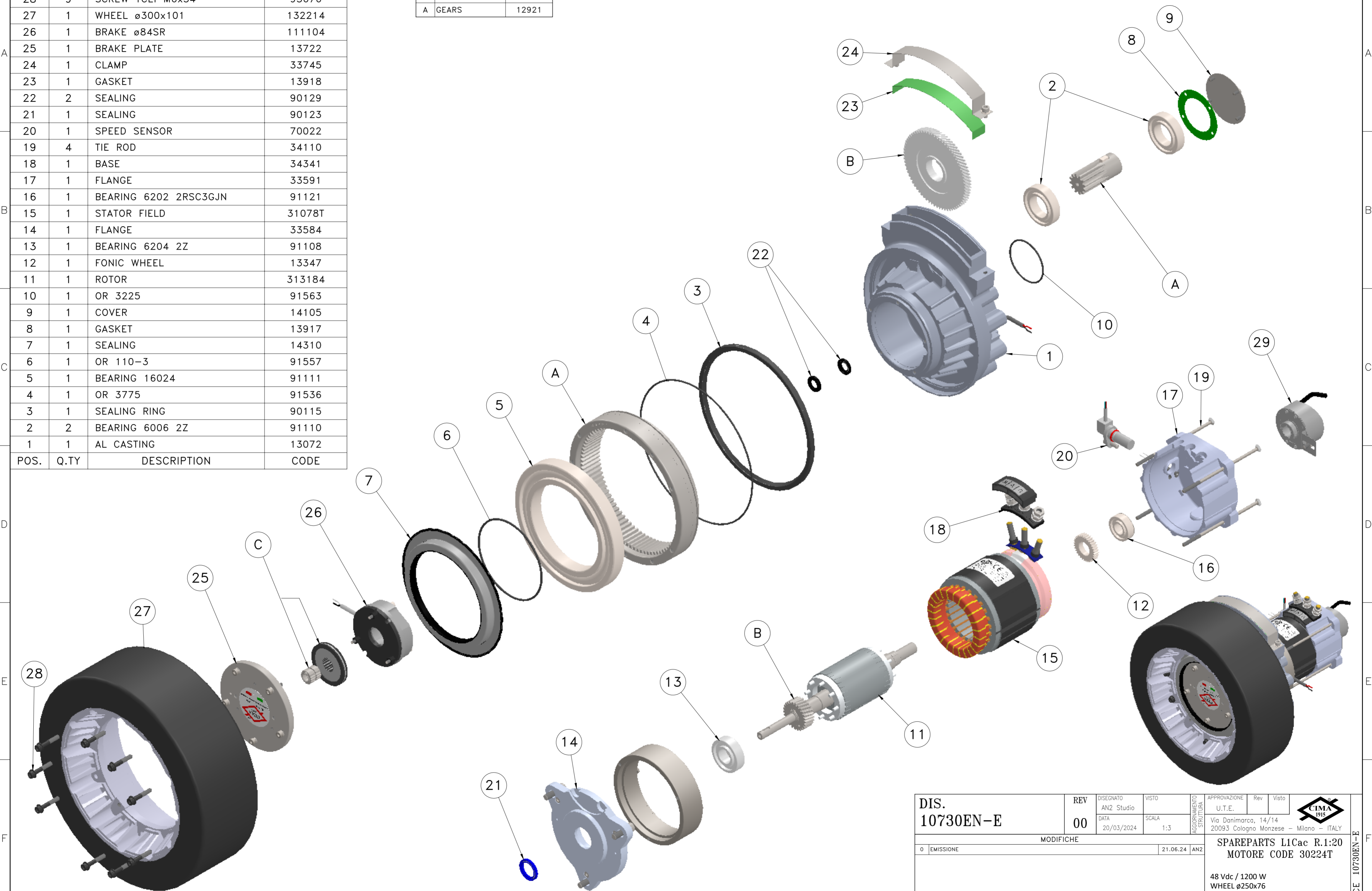

DIS. <b>10730EN-E</b>	REV	00	DISEGNATO	AN2 Studio	VISTO		APPROVAZIONE	U.T.E.	Rev	Visto	
	DATA	20/03/2024	SCALA	1:3	AGGIORNAMENTO STRUTTURA		Via Danimarca, 14/14 20093 Cologno Monzese - Milano - ITALY				
MODIFICHE							21.06.24		AN2		<b>SPAREPARTS L1Cac R.1:20</b> <b>MOTORE CODE 30224T</b>  48 Vdc / 1200 W WHEEL ø250x76 ELAST. ANTISKID BLACK 75sh Project Nr. 2400004/301
0 EMISSIONE											

CODICE 10730EN-E